

# Coordinate Geometry

---

(2025)

1. For a point (3, 5), the value of (abscissa ordinate) is : (1 Mark) (2025)

- (A) 8
- (B) 2
- (C) 2
- (D) 8

2. The mid-point of a line segment divides the line segment in the ratio : (1 Mark) (2025)

- (A) 1 : 2
- (B) 2 : 1
- (C) 1 : 1
- (D)  $\frac{1}{2} : 2$

3. In a society, there is a circular park having two gates. The gates are placed at points A(10, 20) and B(50, 50), as shown in the figure below. Two fountains are installed at points P and Q on AB such that  $AP = PQ = QB$ . (6 Mark) (2025)

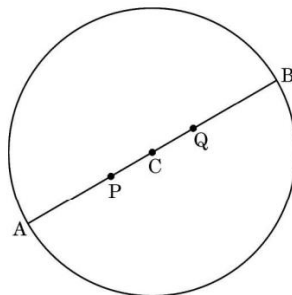

Based on the above information, answer the following questions :

- (i) Find the coordinates of the centre C.
- (ii) Find the radius of the circular park.

(iii) (a) Find the coordinates of the point P.

(b) Find the distance of the fountain at Q from gate A.

4. The mid-point of the line segment joining the points P( 4, 5) and Q(4, 6) lies on :  
(1 Mark) (2025)

(A) x-axis

(B) y-axis

(C) origin

(D) neither x-axis nor y-axis

5. Find the ratio in which the y-axis divides the line segment joining the points (5, 6) and ( 1, 4). Also find the point of intersection. (3 Mark) (2025)

## Answers

1. (D) 8

2. (C) 1 : 1

3.

(i) Co-ordinates of C are  $\left(\frac{10 + 50}{2}, \frac{20 + 50}{2}\right) = C(30, 35)$

(ii) Radius =  $\sqrt{(30 - 10)^2 + (35 - 20)^2} = 25$

(iii) (a) P divides AB in the ratio 1 : 2,

co-ordinates of P are  $\left(\frac{1 \times 50 + 2 \times 10}{3}, \frac{1 \times 50 + 2 \times 20}{3}\right)$

i.e.  $\left(\frac{70}{3}, 30\right)$

(b) Distance AB =  $2 \times 25 = 50$

AQ =  $\frac{2}{3}$ AB =  $\frac{2}{3} \times 50$

AQ =  $\frac{100}{3}$

4. (B) y - axis

5.

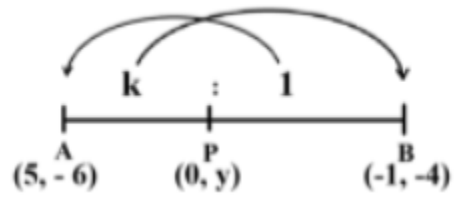

Let the ratio be  $k:1$  and point on  $y$ -axis be  $P(0, y)$

$$0 = \frac{-k+5}{k+1}$$

$$k = 5$$

Hence, ratio is  $5:1$

$$y = \frac{-4(5)-6}{5+1} = \frac{-26}{6} = \frac{-13}{3}$$

Coordinates of point of intersection are  $P\left(0, -\frac{13}{3}\right)$

(2024)

1. The distance between the points (2,-3) and (-2, 3) is: (2024)

- (a)  $2\sqrt{13}$  units
- (b) 5 units
- (c)  $13\sqrt{2}$  units
- (d) 10 units

Answer. (a)  $2\sqrt{13}$  units

2. The diameter of a circle is of length 6 cm. If one end of the diameter is (-4, 0), the other end on x-axis is at : (2024)

- (a) (0,2)
- (b) (6,0)
- (c) (2,0)
- (d) (4,0)

Answer. (c) (2,0)

3.

The mid-point of the line segment joining the points (-1, 3) and  $(8, \frac{3}{2})$  is :

- (a)  $(\frac{7}{2}, -\frac{3}{4})$
- (b)  $(\frac{7}{2}, \frac{9}{2})$
- (c)  $(\frac{9}{2}, -\frac{3}{4})$
- (d)  $(\frac{7}{2}, \frac{9}{4})$

(2024)

Answer. (d)  $(\frac{7}{2}, \frac{9}{4})$

4. In the given figure,  $AP \perp AB$  (2024)

and  $BQ \perp AB$ . If  $OA = 15$  cm,

$BO = 12$  cm and  $AP = 10$  cm,

then find the length of BQ.

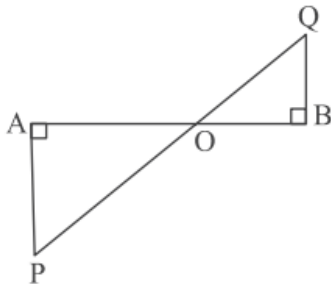

**Answer.**  $\triangle OAP \sim \triangle OBQ$  (AA)

$$\therefore \frac{OA}{OB} = \frac{AP}{BQ} \Rightarrow \frac{15}{12} = \frac{10}{BQ}$$

$$\Rightarrow BQ = 8 \text{ cm.}$$

**5. The line AB intersects x-axis at A and y-axis at B. The point P(2, 3) lies on AB such that AP:PB = 3:1. Find the co-ordinates of A and B. (2024)**

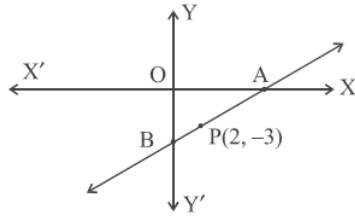

**Answer.** Let co-ordinates of point A be (x, 0) and B(0, y)

$$AP : PB = 3 : 1$$

$$\therefore \frac{x + 0}{4} = 2, \frac{0 + 3y}{4} = -3.$$

$$\Rightarrow x = 8, y = -4$$

$\therefore$  Point A is (8, 0) and B is (0, -4)

**6. To keep the lawn green and cool, Sadhna uses water sprinklers which rotate in circular shape and cover a particular area.**

**The diagram below shows the circular areas covered by two sprinklers: (2024)**

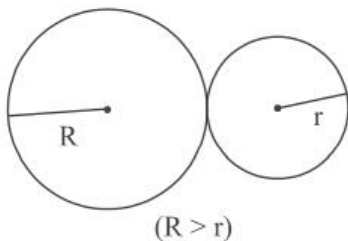

**Two circles touch externally. The sum of their areas is  $130\pi$  sq m and the distance between their centres is 14 m.**

**Based on above information, answer the following questions:**

**(i) Obtain a quadratic equation involving R and r from above. (2024)**

**Answer.**  $R^2 + r^2 = 130$

**(ii) Write a quadratic equation involving only r. (2024)**

**Answer.**  $r^2 - 14r + 33 = 0$

**(iii) (a) Find the radius r and the corresponding area irrigated. (2024)**

**Answer.** (a)  $r^2 - 14r + 33 = 0 \Rightarrow (r - 11)(r - 3) = 0$

$\Rightarrow r = 3 \text{ m}, r \neq 11 \text{ m (As } r < R)$

Corresponding area irrigated =  $9\pi \text{ m}^2$

**OR**

**(b) Find the radius R and the corresponding area irrigated. (2024)**

**Answer.** (b)  $R^2 - 14R + 33 = 0 \Rightarrow (R - 11)(R - 3) = 0$

$\Rightarrow R = 11 \text{ m}, R \neq 3 \text{ (As } R > r)$

Corresponding area irrigated =  $121\pi \text{ m}^2$

**7. AD is a median of AABC with vertices A(5, 6), B(6, 4) and C(0, 0). Length AD is equal to : (2024)**

(a)  $\sqrt{68}$  units

(b)  $2\sqrt{15}$  units

(c)  $\sqrt{101}$  units

(d) 10 units

**Answer.** (a)  $\sqrt{68}$  units

**8. If the distance between the points (3,-5) and (x,-5) is 15 units, then the values of x are: (2024)**

(a) 12,-18

(b) -12, 18

(c) 18,5

(d) -9,-12

**Answer.** (b) -12, 18

**9. The centre of a circle is at (2, 0). If one end of a diameter is at (6, 0), then**

the other end is at : (2024)

- (a) (0,0)
- (b) (4,0)
- (c) (-2, 0)
- (d) (-6, 0)

Answer. (c) (- 2, 0)

10.

(A) Find the ratio in which the point  $\left(\frac{8}{5}, y\right)$  divides the line segment joining the points (1, 2) and (2, 3). Also, find the value of y. (2024)

Answer.

Let AP: PB = k : 1

$$\therefore \frac{2k+1}{k+1} = \frac{8}{5}$$

$$\Rightarrow k = \frac{3}{2}$$

$\therefore$  required ratio is 3: 2.

$$y = \frac{3 \times 3 + 2 \times 2}{3 + 2} = \frac{13}{5}$$

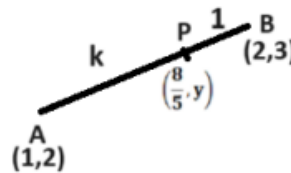

OR

(B) ABCD is a rectangle formed by the points A (-1, -1), B (-1, 6), C (3, 6) and D (3, -1). P, Q, R and S are mid-points of sides AB, BC, CD and DA respectively. Show that diagonals of the quadrilateral PQRS bisect each other. (2024)

Answer.

Co-ordinates of point P are  $\left(\frac{-1-1}{2}, \frac{-1+6}{2}\right)$  i.e.  $\left(-1, \frac{5}{2}\right)$

Co-ordinates of point Q are  $\left(\frac{-1+3}{2}, \frac{6+6}{2}\right)$  i.e.  $(1, 6)$

Co-ordinates of point R are  $\left(\frac{3+3}{2}, \frac{6-1}{2}\right)$  i.e.  $\left(3, \frac{5}{2}\right)$

Co-ordinates of point S are  $\left(\frac{-1+3}{2}, \frac{-1-1}{2}\right)$  i.e.  $(1, -1)$

Co-ordinates of mid point of diagonal QS are  $\left(\frac{1+1}{2}, \frac{6-1}{2}\right)$  i.e.  $\left(1, \frac{5}{2}\right)$

Co-ordinates of mid point of diagonal PR are  $\left(\frac{-1+3}{2}, \frac{\frac{5}{2}+\frac{5}{2}}{2}\right)$  i.e.  $\left(1, \frac{5}{2}\right)$

Since coordinates of mid point of QS = coordinates of mid point of PR  
Therefore, diagonals PR and QS bisect each other.

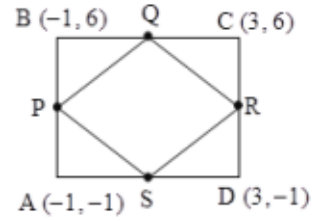

## 7.1 Introduction

### MCQ

1. The distance of the point  $(-1, 7)$  from x-axis is

- (a) -1
- (b) 7
- (c) 6
- (d)  $\sqrt{50}$  (2023)

2. Assertion (A): Point  $P(0, 2)$  is the point of intersection of y-axis with the line  $3x + 2y = 4$ .

Reason (R): The distance of point  $P(0, 2)$  from x-axis is 2 units.

- (a) Both Assertion (A) and Reason (R) are true and Reason (R) is the correct explanation of Assertion (A).
- (b) Both Assertion (A) and Reason (R) are true, but Reason (R) is not the correct explanation of the Assertion (A).
- (c) Assertion (A) is true, but Reason (R) is false.
- (d) Assertion (A) is false but Reason (R) is true. (2023)

3. The line represented by  $4x - 3y = 9$  intersects the y-axis at

- (a)  $(0, -3)$
- (b)  $\left(\frac{9}{4}, 0\right)$
- (c)  $(-3, 0)$
- (d)  $\left(0, \frac{9}{4}\right)$

(Term I, 2021-22)

## 7.2 Distance Formula

### MCQ

4. The distance of the point  $(-6, 8)$  from origin is

- (a) 6

- (c) 8
- (b) -6
- (d) 10 (2023)

5. The points  $(-4, 0)$ ,  $(4, 0)$  and  $(0, 3)$  are the vertices of a

- (a) right triangle
- (b) isosceles triangle
- (c) equilateral triangle
- (d) scalene triangle (2023)

6. The point on x-axis equidistant from the points  $P(5,0)$  and  $Q(-1, 0)$  is

- (a)  $(2,0)$
- (b)  $(-2,0)$
- (c)  $(3,0)$
- (d)  $(2, 2)$  (Term I, 2021-22)

7. The x-coordinate of a point P is twice its y-coordinate. If P is equidistant from  $Q(2, -5)$  and  $R(-3, 6)$ , then the coordinates of P are

- (a)  $(8, 16)$
- (b)  $(10,20)$
- (c)  $(20, 10)$
- (d)  $(16,8)$  (Term I, 2021-22)

8. If the point  $(x, 4)$  lies on a circle whose centre is at the origin and radius is 5 cm, then the value of x is

- (a) 0
- (b) +4
- (c) +5
- (d)  $\pm 3$  (Term I, 2021-22)

9. The distance between the points  $(m, -n)$  and  $(-m, n)$  is

- (a)  $\sqrt{m^2+n^2}$
- (b)  $m+n$
- (c)  $2\sqrt{m^2+n^2}$
- (d)  $\sqrt{2m^2+2n^2}$  (2020)

10. The distance between the points  $(0, 0)$  and  $(a - b, a+b)$  is

- (a)  $2\sqrt{ab}$
- (b)  $\sqrt{2a^2 + ab}$

- (c)  $2\sqrt{a^2+b^2}$   
(d)  $\sqrt{2a^2+2b^2}$  (2020 C)

11. ABCD is a rectangle whose three vertices are B(4, 0), C(4, 3) and D(0, 3). The length of one of its diagonals is

- (a) 5  
(b) 4  
(c) 3  
(d) 25 (AI 2014)

12. The perimeter of a triangle with vertices (0, 4), (0, 0) and (3, 0) is

- (a)  $7+\sqrt{5}$   
(b) 5  
(c) 10  
(d) 12 (Foreign 2014)

**VSA (1 mark)**

13. AOB is a rectangle whose three vertices are A(0, -3), O(0, 0) and B(4, 0). The length of its diagonal is (2020)

14. Find the value(s) of x, if the distance between the points A(0, 0) and B(x, -4) is 5 units. (2019) An

15. Find the distance of a point P(x, y) from the origin. (2018) R

16. If the distance between the points (4, k) and (1, 0) is 5, then what can be the possible values of k? (Delhi 2017)

**SAI (2 marks)**

17. If the distances of P(x, y) from A(5, 1) and B(-1, 5) are equal, then prove that  $3x = 2y$ . (AI 2017)

18. The x-coordinate of a point P is twice its y-coordinate. If P is equidistant from Q(2, -5) and R(-3, 6), find the coordinates of P. (Delhi 2016)

19. Prove that the points (3, 0), (6, 4) and (-1, 3) are the vertices of a right angled isosceles triangle. (AI 2016)

20. Prove that the points (2, -2), (-2, 1) and (5, 2) are the vertices of a right angled triangle. Also find the area of this triangle. (Foreign 2016)

21. If  $A(5, 2)$ ,  $B(2, -2)$  and  $C(-2, t)$  are the vertices of a right angled triangle with  $B = 90^\circ$ , then find the value of  $t$ . (Delhi 2015)
22. The points  $A(4, 7)$ ,  $B(p, 3)$  and  $C(7, 3)$  are the vertices of a right triangle, right-angled at  $B$ . Find the value of  $p$ . (AI 2015)
23. If  $A(4, 3)$ ,  $B(-1, y)$  and  $C(3, 4)$  are the vertices of a right triangle  $ABC$ , right-angled at  $A$ , then find the value of  $y$ . (AI 2015)
24. Show that the points  $(a, a)$ ,  $(-a, -a)$  and  $(-\sqrt{3}a, \sqrt{3}a)$  are the vertices of an equilateral triangle. (Foreign 2015)

**SA II (3 marks)**

25. The centre of a circle is  $(2a, a - 7)$ . Find the values of ' $a$ ' if the circle passes through the point  $(11, -9)$ . Radius of the circle is  $5\sqrt{2}$  cm. (2023)
26. Show that the points  $(7, 10)$ ,  $(-2, 5)$  and  $(3, -4)$  are vertices of an isosceles right triangle. (2020)
27. Find the point on  $y$ -axis which is equidistant from the points  $(5, -2)$  and  $(-3, 2)$ . (Delhi 2019)
28. Show that  $(a, a)$ ,  $(-a, -a)$  and  $(-\sqrt{3}a, \sqrt{3}a)$  are vertices of an equilateral triangle. (2019C)
29. Show that  $\triangle ABC$ , where  $A(-2, 0)$ ,  $B(2, 0)$ ,  $C(0, 2)$  and  $\triangle PQR$ , where  $P(-4, 0)$ ,  $Q(4, 0)$ ,  $R(0, 4)$  are similar triangles. (Delhi 2017)
30. If the point  $P(x, y)$  is equidistant from the points  $A(a + b, b - a)$  and  $B(a - b, a + b)$ . Prove that  $bx = ay$ . (AI 2016)
31. If the point  $A(0, 2)$  is equidistant from the points  $B(3, p)$  and  $C(p, 5)$ , find  $p$ . Also find the length of  $AB$ . (Delhi 2014)
32. Points  $A(-1, y)$  and  $B(5, 7)$  lie on a circle with centre  $O(2, -3y)$ . Find the values of  $y$ . Hence find the radius of the circle. (Delhi 2014)
33. If the point  $P(2, 2)$  is equidistant from the points  $A(-2, k)$  and  $B(-2k, -3)$ , find  $k$ . Also find the length of  $AP$ . (Delhi 2014)
34. If the point  $P(k - 1, 2)$  is equidistant from the points  $A(3, k)$  and  $B(k, 5)$ , find the values of  $k$ . (AI 2014)

35. Find a point P on the y-axis which is equidistant from the points A(4, 8) and B(-6, 6). Also find the distance AP. (AI 2014)

**LA (4/5/6 marks)**

36. The base BC of an equilateral triangle ABC lies on y-axis. The coordinates of point C are (0, -3). The origin is the mid-point of the base. Find the coordinates of the points A and B. Also find the coordinates of another point D such that BACD is a rhombus. (Foreign 2015)

37. The base QR of an equilateral triangle PQR lies on x-axis. The coordinates of point Q are (-4, 0) and the origin is the mid-point of the base. Find the coordinates of the points P and R. (Foreign 2015)

### **7.3 Section Formula**

#### **MCQ**

38. In what ratio, does x-axis divide the line segment joining the points A(3, 6) and B(-12, -3)?

- (a) 1:2
- (b) 1:4
- (c) 4:1
- (d) 2:1 (2023)

39. The ratio in which the point (-4, 6) divides the line segment joining the points A(-6, 10) and B(3, -8) is

- (a) 2:5
- (b) 7:2
- (c) 2:7
- (d) 5:2 (Term I, 2021-22)

Case Study: Shivani is an interior decorator. To design her own living room, she designed wall shelves. The graph of intersecting wall shelves is given below:

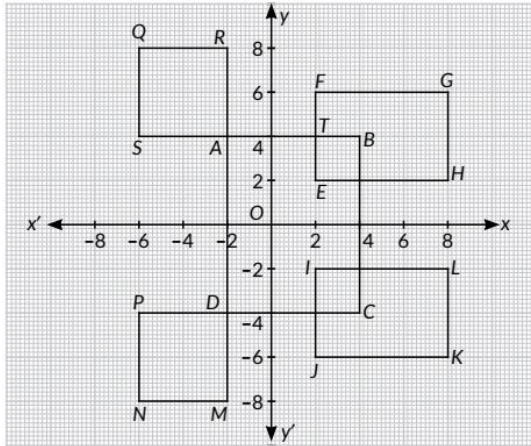

Based on the above information, answer the following questions:

40. If O is the origin, then what are the coordinates of S?

- (a)  $(-6, -4)$
- (b)  $(6, 4)$
- (c)  $(-6, 4)$
- (d)  $(6, -4)$  (Term I, 2021-22)

41. The coordinates of the mid-point of the line segment joining D and H is

- (a)  $(-3, \frac{2}{3})$
- (b)  $(3, -1)$
- (c)  $(3, 1)$
- (d)  $(-3, -\frac{2}{3})$

(Term I, 2021-22)

42. The ratio in which the x-axis divides the line- segment joining the points A and C is

- (a) 2:3
- (b) 2:1
- (c) 1:2
- (d) 1:1 (Term 1, 2021-22)

43. The distance between the points P and G is

- (a) 16 units
- (b)  $3\sqrt{74}$  units
- (c)  $2\sqrt{74}$  units
- (d)  $\sqrt{74}$  units (Term I, 2021-22)

44. The coordinates of the vertices of rectangle IJKL are

- (a)  $I(2, 0), J(2, 6), K(8, 6), L(8, 2)$

- (b)  $1(2,-2)$ ,  $J(2, -6)$ ,  $K(8, -6)$ ,  $L(8,-2)$
- (c)  $(-2, 0)$ ,  $J(-2, 6)$ ,  $K(-8, 6)$ ,  $L(-8, 2)$
- (d)  $(-2, 0)$ ,  $J(-2, -6)$ ,  $K(-8, -6)$ ,  $L(-8,-2)$  (Term I, 2021-22)

45. Case Study: Students of a school are standing in rows and columns in their school playground to celebrate their annual sports day. A, B, C and D are the positions of four students as shown in the figure.

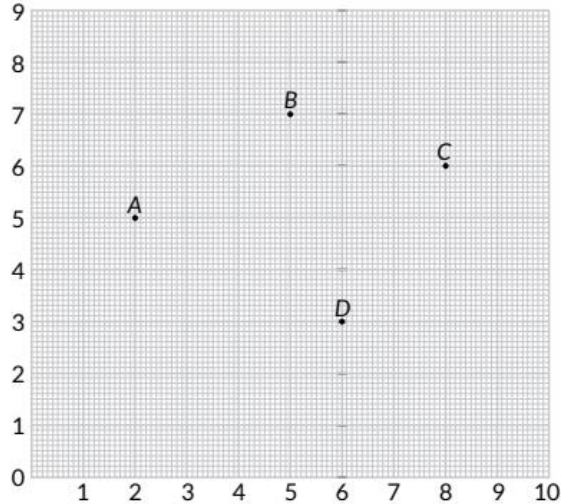

Based on the above, answer the following questions:

I. The figure formed by the four points A, B, C and D is a

- (a) square
- (b) parallelogram
- (c) rhombus
- (d) quadrilateral

II. If the sports teacher is sitting at the origin, then which of the four students is closest to him?

- (a) A
- (b) B
- (c) C
- (d) D

III. The distance between A and C is

- (a)  $\sqrt{37}$  units
- (b)  $\sqrt{35}$  units
- (c) 6 units
- (d) 5 units

IV. The coordinates of the mid-point of line segment AC are

- (a)  $\left(\frac{5}{2}, 11\right)$  (b)  $\left(\frac{5}{2}, \frac{11}{2}\right)$  (c)  $\left(5, \frac{11}{2}\right)$  (d)  $(5, 11)$

V. If a point P divides the line segment AD in the ratio 1:2, then coordinates of P are

- (a)  $\left(\frac{8}{3}, \frac{8}{3}\right)$  (b)  $\left(\frac{10}{3}, \frac{13}{3}\right)$   
(c)  $\left(\frac{13}{3}, \frac{10}{3}\right)$  (d)  $\left(\frac{16}{3}, \frac{11}{3}\right)$  (2021C)

46. The point on the x-axis which is equidistant from  $(-4, 0)$  and  $(10, 0)$  is

- (a)  $(7, 0)$   
(b)  $(5, 0)$   
(c)  $(0, 0)$   
(d)  $(3, 0)$  (2020)

47. If the point  $P(k, 0)$  divides the line segment joining the points  $A(2, -2)$  and  $B(-7, 4)$  in the ratio 1:2, then the value of k is

- (a) 1  
(b) 2  
(c) -2  
(d) -1 (2020)

48. The centre of a circle whose end points of a diameter are  $(-6, 3)$  and  $(6, 4)$  is

- (a)  $(8, -1)$  (b)  $(4, 7)$   
(c)  $\left(0, \frac{7}{2}\right)$  (d)  $\left(4, \frac{7}{2}\right)$  (2020)

**VSA (1 mark)**

49. Find the coordinates of a point A, where AB is a diameter of the circle with centre  $(-2, 2)$  and B is the point with coordinates  $(3, 4)$ . (Delhi 2019)

50. In what ratio is the line segment joining the points  $P(3, -6)$  and  $Q(5, 3)$  divided by x-axis? (2019C)

**SAI (2 marks)**

51. Find the ratio in which the segment joining the points (1, 3) and (4, 5) is divided by x-axis? Also find the coordinates of this point on x-axis. (Delhi 2019)

52. The point R divides the line segment AB, where

$A(-4, 0)$  and  $B(0, 6)$  such that  $AR = \frac{3}{4}AB$ . Find the coordinates of R. (2019) 

coordinates of R. (2019)

53. Find the coordinates of a point A, where AB is a diameter of the circle with centre (3, -1) and the point B is (2, 6). (AI 2019)

54. Find the ratio in which  $P(4, m)$  divides the line segment joining the points  $A(2, 3)$  and  $B(6, -3)$ . Hence find m. (2018)

55. A line intersects the y-axis and x-axis at the points P and Q respectively. If (2, -5) is the mid-point of PQ, then find the coordinates of P and Q. (AI 2017)

56. Find the ratio in which y-axis divides the line segment joining the points  $A(5, -6)$  and  $B(-1, -4)$ . Also find the coordinates of the point of division. (Delhi 2016)

57. Let P and Q be the points of trisection of the line segment joining the points  $A(2, -2)$  and  $B(-7, 4)$  such that P is nearer to A. Find the coordinates of P and Q. (NCERT, AI 2016)

58. Find the ratio in which the point (-3, k) divides the line segment joining the points (-5, -4) and (-2, 3). Also find the value of k. (Foreign 2016)

59.

Find the ratio in which the point  $P\left(\frac{3}{4}, \frac{5}{12}\right)$  divides

the line segment joining the points  $A\left(\frac{1}{2}, \frac{3}{2}\right)$  and

$B(2, -5)$ . (NCERT Exemplar, Delhi 2015) 

**SA II (3 marks)**

60. Find the ratio in which the y-axis divides the line segment joining the points (6, -4) and (-2, -7). Also, find the point of intersection. (2020)

61. If the point  $C(-1, 2)$  divides internally the line segment joining  $A(2, 5)$  and  $B(x, y)$  in the ratio 3: 4, find the coordinates of  $B$ . (2020)

62. The line segment joining the points  $A(2, 1)$  and  $B(5, -8)$  is trisected at the points  $P$  and  $Q$  such that  $P$  is nearer to  $A$ . If  $P$  also lies on the line given by  $2xy + k = 0$ , find the value of  $k$ . (Delhi 2019)

OR

Point  $P$  divides the line segment joining the points  $A(2, 1)$  and  $B(5, -8)$  such that  $\frac{AP}{AB} = \frac{1}{3}$ . If  $P$  lies on the line  $2x - y + k = 0$ , find the value of  $k$ . (AI 2019)

63. Find the ratio in which the line  $x - 3y = 0$  divides the line segment joining the points  $(-2, -5)$  and  $(6, 3)$ . Find the coordinates of the point of intersection. (2019)

64. In what ratio does the point  $P(-4, y)$  divide the line segment joining the points  $A(-6, 10)$  and  $B(3, -8)$ ? Hence find the value of  $y$ . (2019)

65. If  $A(-2, 1)$ ,  $B(a, 0)$ ,  $C(4, b)$  and  $D(1, 2)$  are the vertices of a parallelogram  $ABCD$ , find the values of  $a$  and  $b$ . Hence find the lengths of its sides. (2018)

66.

In what ratio does the point  $\left(\frac{24}{11}, y\right)$  divide the line segment joining the points  $P(2, -2)$  and  $Q(3, 7)$ ? Also find the value of  $y$ . (AI 2017)

67. If the point  $C(-1, 2)$  divides internally the line-segment joining the points  $A(2, 5)$  and  $B(x, y)$  in the ratio 3: 4, find the value of  $x^2 + y^2$ . (Foreign 2016)

68. If the coordinates of points  $A$  and  $B$  are  $(-2, -2)$  and  $(2, -4)$  respectively, find the coordinates

of  $P$  such that  $AP = \frac{3}{7}AB$ , where  $P$  lies on the line segment  $AB$ . (NCERT, AI 2015) 

69. Find the coordinates of a point  $P$  on the line segment

joining  $A(1, 2)$  and  $B(6, 7)$  such that  $AP = \frac{2}{5}AB$ . (AI 2015)

70. Point A lies on the line segment PQ joining P(6,-6)

and Q(-4,-1) in such a way that  $\frac{PA}{PQ} = \frac{2}{5}$ . If point P

also lies on the line  $3x + k(y + 1) = 0$ , find the value of k. (Foreign 2015)

71. Find the ratio in which the line segment joining the points A(3, -3) and B(-2, 7) is divided by x-axis. Also find the coordinates of the point of division. (AI 2014)

72. Prove that the diagonals of a rectangle ABCD, with vertices A(2, -1), B(5, -1), C(5, 6) and D(2, 6), are equal and bisect each other. (AI 2014)

73. Points P, Q, R and S divide the line segment joining the points A(1, 2) and B(6, 7) in 5 equal parts. Find the coordinates of the points P, Q and R. (Foreign 2014)

**LA (4/5/6 marks)**

74. Case Study: Jagdish has a field which is in the shape of a right angled triangle AQC. He wants to leave a space in the form of a square PQRS inside the field for growing wheat and the remaining for growing vegetables (as shown in the figure). In the field, there is a pole marked as O.

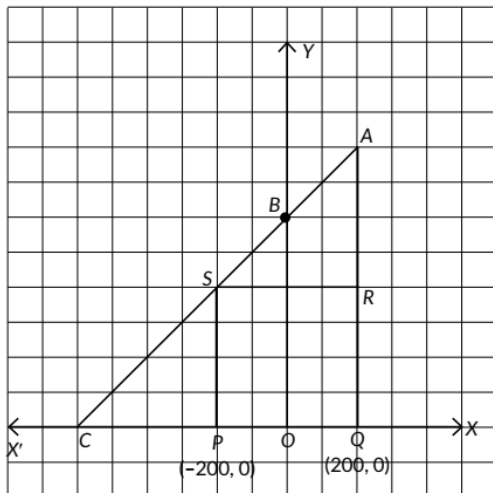

Based on the above information, answer the following questions:

(i) Taking O as origin, coordinates of P are (-200, 0) and of Q are (200, 0).

PQRS being a square, what are the coordinates of R and S?

(ii) (a) What is the area of square PQRS?

**OR**

- (b) What is the length of diagonal PR in square PQRS?  
(iii) If S divides CA in the ratio K: 1, what is the value of K, where point A is (200, 800) ? (2023)

75. Find the ratio in which the point P(x, 2) divides the line segment joining the points A(12, 5) and B(4, -3). Also find the value of x.  
(Delhi 2014)

76. The mid-point P of the line segment joining the points A(-10, 4) and B(-2, 0) lies on the line segment joining the points C(-9, -4) and D(-4, y). Find the ratio in which P divides CD. Also find the value of y. (Foreign 2014)

## CBSE Sample Questions

### 7.2 Distance Formula

#### MCQ

1. In the question, a statement of Assertion (A) is followed by a statement of Reason (R). Choose the correct option.

Statement A (Assertion): If the co-ordinates of the mid-points of the sides AB and AC of  $\triangle ABC$  are D(3, 5) and E(-3, -3) respectively, then  $BC = 20$  units.

Statement R (Reason): The line joining the mid points of two sides of a triangle is parallel to the third side and equal to half of it.

- (a) Both assertion (A) and reason (R) are true and reason (R) is the correct explanation of assertion (A).  
(b) Both assertion (A) and reason (R) are true and reason (R) is not the correct explanation of assertion (A).  
(c) Assertion (A) is true but reason (R) is false.  
(d) Assertion (A) is false but reason (R) is true. (2022-23)

2. The distance of the point A(-5, 6) from the origin is

- (a) 11 units  
(b) 61 units  
(c)  $\sqrt{11}$  units  
(d)  $\sqrt{61}$  units (Term I, 2021-22)

3. The equation of the perpendicular bisector of line segment joining points A(4, 5) and B(-2, 3) is

- (a)  $2x - y + 7 = 0$

- (b)  $3x+2y-7=0$
- (c)  $3x-y-7=0$
- (d)  $3x + y -7=0$  (Term I, 2021-22)

**SAI (2 marks)**

4. Find the point on x-axis which is equidistant from the points (2,-2) and (-4, 2). (2020-21)

**7.3 Section Formula**

**MCQ**

5. If the vertices of a parallelogram PQRS taken in order are P(3, 4), Q(-2, 3) and R(-3, -2), then the coordinates of its fourth vertex S are

- (a) (-2, -1)
- (b) (-2,-3)
- (c) (2,-1)
- (d) (1, 2) (2022-23)

6. The vertices of a parallelogram in order are A(1, 2), B(4, y), C(x, 6) and D (3, 5). Then (x, y) is

- (a) (6,3)
- (b) (3,6)
- (c) (5,6)
- (d) (1,4) (Term I, 2021-22)

7. Point P divides the line segment joining R(-1, 3) and S(9, 8) in ratio k: 1. If P lies on the line  $x - y + 2 = 0$ , then value of k is

- (a)  $\frac{2}{3}$
  - (b)  $\frac{1}{2}$
  - (c)  $\frac{1}{3}$
  - (d)  $\frac{1}{4}$
- (Term I, 2021-22)

Case Study: A hockey field is the playing surface for the game of hockey.

Historically, the game was played on natural turf (grass) but nowadays it is predominantly played on an artificial turf.

It is rectangular in shape - 100 yards by 60 yards. Goals consist of two upright posts placed equidistant from the centre of the backline, joined at the top by a horizontal cross-bar. The inner edges of the posts must be 3.66 metres (4 yards) apart, and the lower edge of the crossbar must be 2.14 metres (7 feet) above the ground. Each team plays with 11 players on the field during the

game including the goalie. Positions you might play include-

- Forward: As shown by players A, B, C and D.
- Midfielders: As shown by players E, F and G
- Fullbacks: As shown by players H, I and J
- Goalie: As shown by player K

Using the picture of hockey field below, answer the questions that follow:

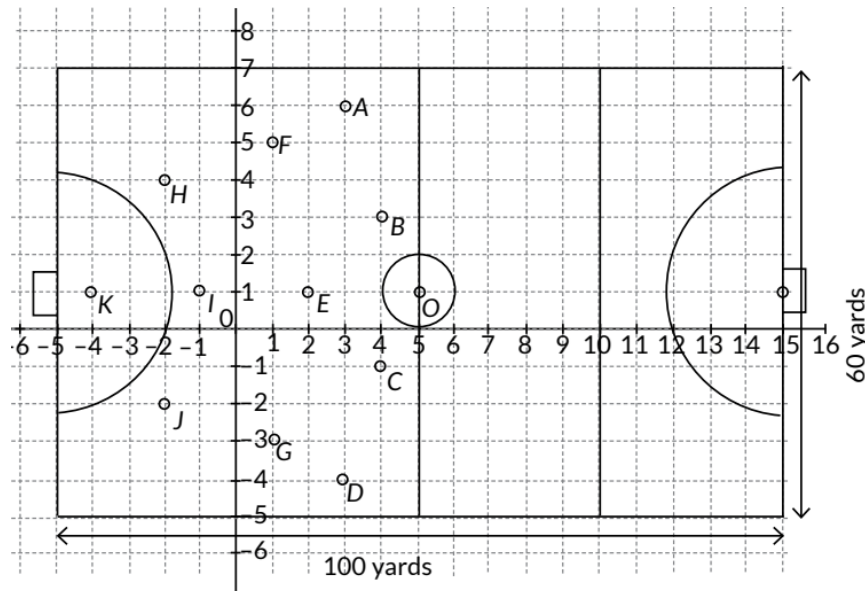

8. The coordinates of the centroid of AEHJ are

- (a)  $\left(\frac{-2}{3}, 1\right)$  (b)  $\left(1, \frac{-2}{3}\right)$  (c)  $\left(\frac{2}{3}, 1\right)$  (d)  $\left(\frac{-2}{3}, -1\right)$

(Term I, 2021-22)

9. If a player P needs to be at equal distances from A and G, such that A, P and G are in straight line, then position of P will be given by

- (a)  $\left(\frac{-3}{2}, 2\right)$  (b)  $\left(2, \frac{-3}{2}\right)$  (c)  $\left(2, \frac{3}{2}\right)$  (d)  $(-2, -3)$

(Term I, 2021-22)

10. The point on x axis equidistant from I and E is

- (a)  $\left(\frac{1}{2}, 0\right)$  (b)  $\left(0, -\frac{1}{2}\right)$  (c)  $\left(-\frac{1}{2}, 0\right)$  (d)  $\left(0, \frac{1}{2}\right)$

(Term I, 2021-22)

11. What are the coordinates of the position of a player Q such that his distance from K is twice his distance from E and K, Q and E are collinear?

- (a) (1, 0)
- (b) (0, 1)
- (c) (-2, 1)
- (d) (-1, 0) (Term I, 2021-22)

12. The point on y-axis equidistant from B and C is

- (a) (-1, 0)
- (b) (0, -1)
- (c) (1,0)
- (d) (0, 1) (Term I, 2021-22)

Case study-based questions are compulsory. Attempt any 4 sub parts from given question. Each question carries 1 mark.

13. Sun Room: The diagrams show the plans for a sun room. It will be built onto the wall of a house. The four walls of the sunroom are square clear glass panels. The roof is made using

- Four clear glass panels, trapezium in shape, all the same size
- One tinted glass panel, half a regular octagon in shape.

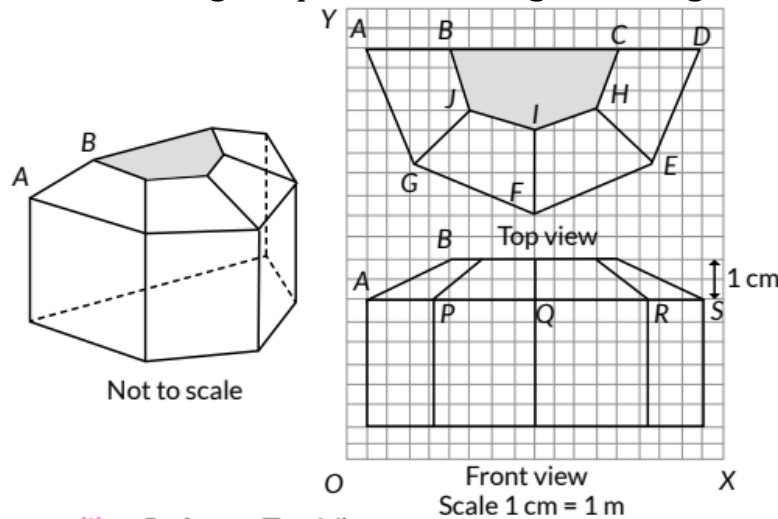

(i) Refer to Top View

Find the mid-point of the segment joining the points J(6, 17) and (9, 16).

- (a)  $(33/2, 15/2)$
- (b)  $(3/2, 1/2)$
- (c)  $(15/2, 33/2)$
- (d)  $(1/2, 3/2)$

(ii) Refer to Top View

The distance of the point P from the y-axis is

- (a) 4
- (b) 15
- (iii) Refer to Front View
- (c) 19
- (d) 25

The distance between the points A and S is

- (a) 4
- (b) 8
- (c) 16
- (d) 20
- (iv) Refer to Front View

Find the co-ordinates of the point which divides the line segment joining the points A and B in the ratio

1:3 internally.

- (a) (8.5, 2.0)
- (b) (2.0, 9.5)
- (c) (3.0, 7.5)
- (d) (2.0, 8.5)

(v) Refer to Front View

If a point  $(x, y)$  is equidistant from the  $Q(9, 8)$  and  $S(17, 8)$ , then

- (a)  $x + y = 13$
- (b)  $x - 13 = 0$
- (c)  $y - 13 = 0$
- (d)  $x - y = 13$  (2020-21)

### SAI (2 marks)

14. P  $(-2, 5)$  and Q  $(3, 2)$  are two points. Find the co-ordinates of the point R on PQ such that  $PR = 2QR$ . (2020-21)

### LA (4/5/6 marks)

Case study-based questions are compulsory. Attempt any 4 sub parts from given question.

15. A tiling or tessellation of a flat surface is the covering of a plane using one or more geometric shapes, called tiles, with no overlaps and no gaps.

Historically, tessellations were used in ancient Rome and in Islamic art. You may find tessellation patterns on floors, walls, paintings etc. Shown below is a

tilled floor in the archaeological Museum of Seville, made using squares, triangles and hexagons.



A craftsman thought of making a floor pattern after being inspired by the above design. To ensure accuracy in his work, he made the pattern on the Cartesian plane. He used regular octagons, squares and triangles for his floor tessellation pattern.

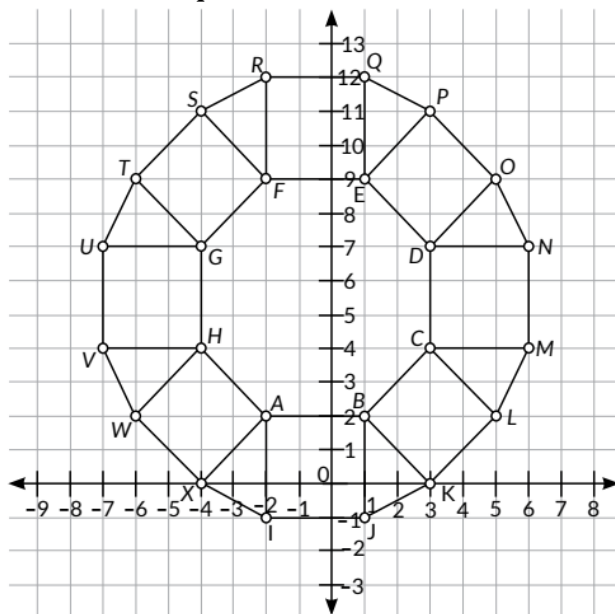

Use the above figure to answer the questions that follow:

- (i) What is the length of the line segment joining points B and F?
- (ii) The centre 'Z' of the figure will be the point of intersection of the diagonals of quadrilateral WXOP. Then what are the coordinates of Z?
- (iii) What are the coordinates of the point on y-axis equidistant from A and G?

**OR**

What is the area of Trapezium AFGH? (2022-23)

## SOLUTIONS

### Previous Years' CBSE Board Questions

- (b): Distance from x-axis = y-coordinate of point = 7 units
- (b): Point P(0, 2) is the point of intersection of y-axis with line  $3x + 2y = 4$ .

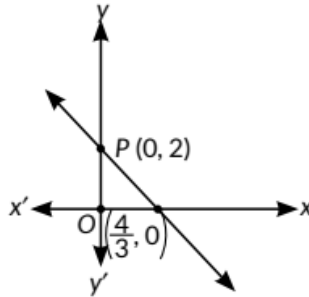

Also, the distance of point P(0, 2) from x-axis is 2 units.

∴ Both assertion and Reason are true but Reason is not the correct explanation of Assertion.

3. (a): Given, the equation of line is  $4x - 3y = 9$ .

Putting  $x = 0$ , we get  $4x - 3y = 9 \Rightarrow y = -3$

So, the line  $4x - 3y = 9$  intersects the y-axis at (0, -3).

4. (d): Distance of the point (-6, 8) from origin (0, 0)

$$= \sqrt{(-6-0)^2 + (8-0)^2} = \sqrt{36+64} = \sqrt{100} = 10 \text{ units}$$

5. (b): The points be A(-4, 0), B(4, 0) and C(0, 3).

Using distance formula  $d = \sqrt{(x_2 - x_1)^2 + (y_2 - y_1)^2}$

$$AB = \sqrt{(4 - (-4))^2 + (0 - 0)^2} = \sqrt{(4 + 4)^2} = \sqrt{8^2} = 8 \text{ units}$$

$$BC = \sqrt{(0 - 4)^2 + (3 - 0)^2} = \sqrt{16 + 9} = \sqrt{25} = 5 \text{ units}$$

$$CA = \sqrt{(-4 - 0)^2 + (0 - 3)^2} = \sqrt{16 + 9} = \sqrt{25} = 5 \text{ units}$$

And,  $AB^2 + BC^2 + CA^2$

$$BC = CA$$

∴  $\Delta ABC$  is an isosceles triangle.

6. (a): Let coordinates of the point on the x-axis be

R(x, 0).

$$\text{Given, } PR = QR \Rightarrow PR^2 = QR^2$$

$$\begin{aligned}
 &= (x-5)^2 + (0-0)^2 = (x+1)^2 + (0-0)^2 \\
 &= x^2 - 10x + 25 = x^2 + 2x + 1 \Rightarrow 12x = 24 \Rightarrow x = 2 \\
 &\text{Required point is } (2, 0).
 \end{aligned}$$

7. (d): Let y-coordinate of point P = t

So, x-coordinate of point P = 2t. Point is P (2t, t).

Given, PQ = RP  $\Rightarrow$  PQ<sup>2</sup> = RP<sup>2</sup>

$$\Rightarrow (2t-2)^2 + (t+5)^2 = (2t+3)^2 + (t-6)^2 \text{ [By distance formula]}$$

$$\Rightarrow 4t^2 - 8t + 4 + t^2 + 10t + 25 = 4t^2 + 12t + 9 + t^2 - 12t + 36$$

$$\Rightarrow 2t = 16 \Rightarrow t = 8$$

$\therefore$  Coordinates of P are (16, 8).

8. (d): Given, (x, 4) lies on the circle and coordinates of centre is origin i.e. (0, 0)

So, radius =  $\sqrt{(x-0)^2 + (4-0)^2}$

$$= \sqrt{(x-0)^2 + (4-0)^2}$$

$$\Rightarrow 5 = \sqrt{x^2 + 16} \Rightarrow x^2 + 16 = 25 \text{ (Given, radius = 5 cm)}$$

$$\Rightarrow x^2 = 9 \Rightarrow x = \pm 3$$

9. (c): Required distance

$$= \sqrt{(m-(-m))^2 + (-n-n)^2} = \sqrt{(m+m)^2 + (-2n)^2}$$

$$= \sqrt{(2m)^2 + (-2n)^2} = \sqrt{4m^2 + 4n^2} = \sqrt{4(m^2 + n^2)}$$

$$= 2\sqrt{m^2 + n^2}$$

10. (d): Required distance =  $\sqrt{(a-b-0)^2 + (a+b-0)^2}$

$$= \sqrt{(a-b)^2 + (a+b)^2} = \sqrt{a^2 + b^2 - 2ab + a^2 + b^2 + 2ab}$$

$$= \sqrt{2a^2 + 2b^2}$$

11. (a) ABCD is a rectangle having vertices B(4, 0),

C(4,3) and D(0, 3). Using distance formula,

$$BD = \sqrt{(4-0)^2 + (0-3)^2} = \sqrt{16+9} = 5 \text{ units}$$

12. (d): Let O(0, 0), A(3, 0) and B(0, 4) represent the  $\Delta$ ABO.

$\therefore$  OA = 3 units, OB = 4 units and

$$AB = \sqrt{(3-0)^2 + (0-4)^2} = \sqrt{25} = 5 \text{ units}$$

$\therefore$  Perimeter of  $\Delta$ OAB = OA + OB + BA

$$= 3 + 4 + 5 = 12 \text{ units}$$

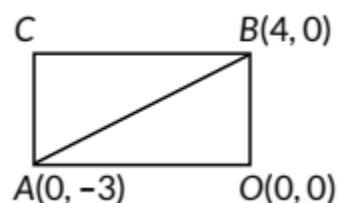

13. In rectangle AOBC, AB is a diagonal.

$$\begin{aligned}\text{So, } AB &= \sqrt{(0-4)^2 + (-3-0)^2} \\ &= \sqrt{4^2 + 3^2} = \sqrt{16+9} = \sqrt{25} = 5 \text{ units}\end{aligned}$$

14. Given  $AB = 5$  units

$$\begin{aligned}\Rightarrow \sqrt{(x-0)^2 + (-4-0)^2} &= 5 \quad (\text{Using distance formula}) \\ \Rightarrow x^2 + (4)^2 &= (5)^2 \Rightarrow x^2 + 16 = 25 \Rightarrow x^2 = 9 \Rightarrow x = \pm 3\end{aligned}$$

15. Distance of point  $P(x, y)$  from the origin  $O(0, 0)$  is given by

$$OP = \sqrt{(x-0)^2 + (y-0)^2} = \sqrt{x^2 + y^2}.$$

16. Let  $A(4, k)$  and  $B(1, 0)$ .

Also,  $AB = 5$  (Given)

$$\begin{aligned}\therefore \text{ By using distance formula, } \sqrt{(1-4)^2 + (0-k)^2} &= 5 \\ \Rightarrow 9 + k^2 &= 25 \Rightarrow k^2 = 16 \Rightarrow k = \pm 4\end{aligned}$$

17. We have,  $P(x, y)$ ,  $A(5, 1)$  and  $B(-1, 5)$

Given,  $PA = PB$

$$\begin{aligned}\Rightarrow \sqrt{(x-5)^2 + (y-1)^2} &= \sqrt{(x+1)^2 + (y-5)^2} \\ &= x^2 + 25 - 10x + y^2 + 1 - 2y = x^2 + 1 + 2x + y^2 + 25 - 10y \\ &= -10x - 2y = 2x - 10y \Rightarrow 12x = -8y \Rightarrow 3x = 2y\end{aligned}$$

18. Let the required point be  $P(2y, y)$ .

Since  $P(2y, y)$  is equidistant from given points  $Q(2, -5)$  and  $R(-3, 6)$ .

$$\begin{aligned}\therefore PQ &= PR \Rightarrow PQ^2 = PR^2 \\ \Rightarrow (2y-2)^2 + (y+5)^2 &= (-3-2y)^2 + (6-y)^2 \\ \Rightarrow 4y^2 + 4 - 8y + y^2 + 25 + 10y &= 9 + 4y^2 + 12y + 36 + y^2 - 12y \\ \Rightarrow 2y &= 16 \Rightarrow y = 8\end{aligned}$$

Hence, the required point  $P$  is  $(16, 8)$ .

19. Let  $A(3, 0)$ ,  $B(6, 4)$  and  $C(-1, 3)$  be the vertices of triangle.

$$\text{Now, } AB = \sqrt{(3-6)^2 + (0-4)^2} = \sqrt{9+16} = 5 \text{ units} \quad (\text{By using distance formula})$$

$$\begin{aligned}AC &= \sqrt{(3+1)^2 + (0-3)^2} = \sqrt{16+9} = 5 \text{ units} \\ &= \sqrt{(6+1)^2 + (4-3)^2} = \sqrt{50} = 5\sqrt{2} \text{ units}\end{aligned}$$

Now, as  $AB = AC$  and  $(AB)^2 + (AC)^2 = (BC)^2$   
 $\therefore$  AABC is a right angled isosceles triangle.

20. Let  $A(2, -2)$ ,  $B(-2, 1)$  and  $C(5, 2)$

$$\text{Now, } AB = \sqrt{(-2-2)^2 + (1+2)^2} = \sqrt{16+9} = \sqrt{25} = 5 \text{ units}$$

$$BC = \sqrt{(5+2)^2 + (2-1)^2} = \sqrt{49+1} = \sqrt{50} = 5\sqrt{2} \text{ units}$$

$$CA = \sqrt{(2-5)^2 + (-2-2)^2} = \sqrt{9+16} = \sqrt{25} = 5 \text{ units}$$

$$\text{Here, } (AB)^2 + (AC)^2 = 25 + 25 = 50 = (BC)^2$$

Hence, AABC is a right angled triangle at A.

$$\therefore \text{ Area of } \Delta ABC = \frac{1}{2} \times 5 \times 5 = \frac{25}{2} \text{ sq. units}$$

21. By using Pythagoras theorem in right angled AABC, we have

$$AC^2 = AB^2 + BC^2$$

$$\Rightarrow (-2-5)^2 + (t-2)^2 = (2-5)^2 + (-2-2)^2 + (-2-2)^2 + (t+2)^2$$

$$\Rightarrow 49 + t^2 - 4t + 4 = 9 + 16 + 16 + t^2 + 4t + 4$$

$$\Rightarrow -8t = -8 \Rightarrow t = 1$$

22. By Pythagoras theorem in AABC, we have  $AB^2 + BC^2 = AC^2$

$$\Rightarrow (p-4)^2 + (3-7)^2 + (7-p)^2 + (3-3)^2 = (7-4)^2 + (3-7)^2$$

$$= p^2 - 8p + 16 + 16 + 49 - 14p + p^2 + 0 = 9 + 16$$

$$\Rightarrow 2p^2 - 22p + 56 = 0 \Rightarrow p^2 - 11p + 28 = 0$$

$$\Rightarrow (p-7)(p-4) = 0 \Rightarrow p = 7 \text{ or } p = 4$$

For  $p = 7$ ,  $BC = \sqrt{(7-7)^2 + (3-3)^2} = 0$  which is not possible.

Hence,  $p = 4$

23. By Pythagoras theorem in AABC, we have

$$AB^2 + AC^2 = BC^2$$

$$\Rightarrow (-1-4)^2 + (y-3)^2 + (3-4)^2 + (4-3)^2 = (3+1)^2 + (4-y)^2$$

$$\Rightarrow 25 + y^2 - 6y + 9 + 1 + 1 = 16 + 16 - 8y + y^2$$

$$\Rightarrow -6y + 8y = 32 - 36 \quad 2y = -4 \Rightarrow y = -2$$

24. Let the vertices be  $A(a, a)$ ,  $B(-a, -a)$  and  $C(-\sqrt{3}a, \sqrt{3}a)$ .

$$\therefore AB = \sqrt{(-a-a)^2 + (-a-a)^2} = \sqrt{4a^2 + 4a^2} = \sqrt{8a^2} = 2\sqrt{2}a$$

$$BC = \sqrt{(-\sqrt{3}a+a)^2 + (\sqrt{3}a+a)^2} = \sqrt{a^2(-\sqrt{3}+1)^2 + a^2(\sqrt{3}+1)^2}$$

$$= a\sqrt{1+3-2\sqrt{3}+3+1+2\sqrt{3}} = a\sqrt{8} = 2\sqrt{2}a$$

$$\text{and } AC = \sqrt{(-\sqrt{3}a-a)^2 + (\sqrt{3}a-a)^2}$$

$$= \sqrt{a^2(\sqrt{3}+1)^2 + a^2(\sqrt{3}-1)^2}$$

$$= a\sqrt{3+1+2\sqrt{3}+3+1-2\sqrt{3}} = a\sqrt{8} = 2\sqrt{2}a$$

Hence,  $AB = BC = CA$

Therefore, ABC is an equilateral triangle.

25. Given centre of a circle is  $(2a, a - 7)$

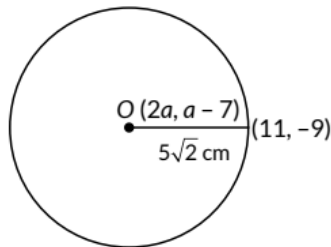

Radius of circle =  $5\sqrt{2}$  cm

$\therefore$  Distance between centre  $(2a, a - 7)$  and  $(11, -9)$   
= radius of circle.

$$\therefore \sqrt{(11-2a)^2 + (-9-a+7)^2} = 5\sqrt{2}$$

$$\Rightarrow (11-2a)^2 + (-2-a)^2 = 25 \times 2 = 50$$

$$\Rightarrow 121 + 4a^2 - 44a + 4 + a^2 + 4a = 50$$

$$\Rightarrow a^2 - 8a + 15 = 0 \Rightarrow (a - 3)(a - 5) = 0 \Rightarrow a = 3 \text{ or } a = 5$$

26. Let the given points be  $A(7, 10)$ ,  $B(-2, 5)$  and  $C(3, -4)$ .

Using distance formula  $\sqrt{(x_2 - x_1)^2 + (y_2 - y_1)^2}$ , we have

$$AB = \sqrt{(7+2)^2 + (10-5)^2} = \sqrt{81+25} = \sqrt{106}$$

$$BC = \sqrt{(-2-3)^2 + (5+4)^2} = \sqrt{25+81} = \sqrt{106}$$

$$CA = \sqrt{(7-3)^2 + (10+4)^2} = \sqrt{16+196} = \sqrt{212}$$

Since,  $AB = BC$ . ABC is an isosceles triangle.

$$\text{Also, } AB^2 + BC^2 = 106 + 106 = 212 = AC^2$$

So, ABC is an isosceles right angled triangle with  $\angle B = 90^\circ$ .

27. Let P(0, y) be the point on the y-axis which is equidistant from A(5, 2) and B(-3, 2).

$$\begin{aligned} \therefore AP = BP &\Rightarrow (AP)^2 = (BP)^2 \\ \Rightarrow (5-0)^2 + (-2-y)^2 &= (-3-0)^2 + (2-y)^2 \\ \Rightarrow 25 + 4 + y^2 + 4y &= 9 + 4 + y^2 - 4y \\ \Rightarrow 8y = 9 - 25 &\Rightarrow y = -\frac{16}{8} = -2 \end{aligned}$$

Hence, A and B are equidistant from (0, -2).

28. Let A(a, a), B(-a, -a), C(-√3a, √3a) be vertices of a triangle.

$$\begin{aligned} \text{Now, } AB &= \sqrt{(-a-a)^2 + (-a-a)^2} = \sqrt{(-2a)^2 + (-2a)^2} \\ &= \sqrt{4a^2 + 4a^2} = \sqrt{8a^2} = 2\sqrt{2}a \\ BC &= \sqrt{(-\sqrt{3}a+a)^2 + (\sqrt{3}a+a)^2} \\ &= \sqrt{3a^2 + a^2 - 2\sqrt{3}a^2 + 3a^2 + a^2 + 2\sqrt{3}a^2} = \sqrt{8a^2} = 2\sqrt{2}a \\ CA &= \sqrt{(a+\sqrt{3}a)^2 + (a-\sqrt{3}a)^2} \\ &= \sqrt{a^2 + 3a^2 + 2\sqrt{3}a^2 + a^2 + 3a^2 - 2\sqrt{3}a^2} = \sqrt{8a^2} = 2\sqrt{2}a \\ \therefore AB &= BC = CA \end{aligned}$$

Hence, A(a, a), B(-a, -a) and C(-√3a, √3a) are vertices of an equilateral triangle.

29. By using distance formula,

$$\begin{aligned} AB &= \sqrt{(2+2)^2 + (0)^2} = 4 \text{ units} \\ BC &= \sqrt{(0-2)^2 + (2-0)^2} = \sqrt{4+4} = 2\sqrt{2} \text{ units} \\ AC &= \sqrt{(0+2)^2 + (2-0)^2} = \sqrt{4+4} = 2\sqrt{2} \text{ units} \\ \text{Similarly, } PQ &= \sqrt{(4+4)^2 + (0)^2} = \sqrt{64} = 8 \text{ units} \\ QR &= \sqrt{(4-0)^2 + (0-4)^2} = \sqrt{16+16} = 4\sqrt{2} \text{ units} \\ PR &= \sqrt{(0+4)^2 + (4-0)^2} = \sqrt{16+16} = 4\sqrt{2} \text{ units} \end{aligned}$$

$$\therefore \frac{AB}{PQ} = \frac{BC}{QR} = \frac{AC}{PR} = \frac{1}{2}$$

Since, sides are proportional.

$$\therefore \triangle ABC \sim \triangle PQR$$

30. Given, A(a + b, b - a) and B(a - b, a + b) are equidistant from P(x, y).

$$\begin{aligned}
&\text{i.e., } PA = PB \Rightarrow (PA)^2 = (PB)^2 \\
&\Rightarrow [x-(a+b)]^2 + [y - (b - a)]^2 = [(x - (a - b))]^2 + [y - (a + b)]^2 \\
&\Rightarrow (a+b)^2 - 2(a + b)x + (b - a)^2 - 2(b - a)y \\
&= (a - b)^2 - 2(a - b)x + (a + b)^2 - 2(a + b)y \\
&\Rightarrow 2[(a + b)x + (b - a)y] = 2[(a - b)x + (a + b)y] \\
&\Rightarrow (a + b)x + (b - a)y = (a - b)x + (a + b)y \\
&\Rightarrow (a + b - a - b)x = (a + b - b + a)y \\
&\Rightarrow 2bx = 2ay \text{ or } bx = ay.
\end{aligned}$$

31. The given points are A(0, 2), B(3, p) and C(p, 5). Since A is equidistant from B and C

$$\begin{aligned}
&\therefore AB = AC \Rightarrow AB^2 = AC^2 \\
&\Rightarrow (3-0)^2 + (p-2)^2 = (p-0)^2 + (5-2)^2 \\
&\Rightarrow 9 + p^2 + 4 - 4p = p^2 + 9 = 4 - 4p = 0 \\
&\Rightarrow 4p = 4 \Rightarrow p = 1
\end{aligned}$$

32. Points A(-1, y) and B(5, 7) lie on a circle with centre O(2, -3y)

$$\begin{aligned}
&\therefore OA = OB \Rightarrow OA^2 = OB^2 \\
&\Rightarrow (2 + 1)^2 + (-3y - y)^2 \\
&\quad = (5 - 2)^2 + (7 + 3y)^2 \\
&\Rightarrow (3)^2 + (-4y)^2 = (3)^2 + (7 + 3y)^2 \\
&\Rightarrow 9 + 16y^2 = 9 + 49 + 9y^2 + 42y \\
&\Rightarrow 7y^2 - 42y - 49 = 0 \Rightarrow y^2 - 6y - 7 = 0 \\
&\Rightarrow y^2 + y - 7y - 7 = 0 \Rightarrow y(y + 1) - 7(y + 1) = 0 \\
&\Rightarrow (y + 1)(y - 7) = 0 \Rightarrow y = -1 \text{ or } y = 7
\end{aligned}$$

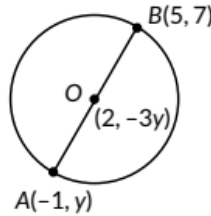

Radius of circle, when

$$\begin{aligned}
&y = -1, \sqrt{9 + 16(-1)^2} = \sqrt{25} = 5 \text{ units} \\
&y = 7, \sqrt{9 + 16(7)^2} = \sqrt{9 + 784} = \sqrt{793} = 28.16 \text{ units (approx.)}
\end{aligned}$$

33. Given, P(2, 2), A(-2, k) and B(-2k, -3)

Since P is equidistant from A and B.

$$\begin{aligned}
&\therefore AP = BP \Rightarrow AP^2 = BP^2 \\
&\Rightarrow (2 + 2)^2 + (2 - k)^2 = (2 + 2k)^2 + (2 + 3)^2 \\
&\Rightarrow 16 + 4 + k^2 - 4k = 4 + 4k^2 + 8k + 25 \\
&\Rightarrow 3k^2 + 12k + 9 = 0 \Rightarrow k^2 + 4k + 3 = 0 \\
&\Rightarrow k^2 + 3k + k + 3 = 0 \Rightarrow k(k + 3) + 1(k + 3) = 0
\end{aligned}$$

$$\Rightarrow (k + 1)(k + 3) = 0 \Rightarrow k = -1 \text{ or } k = -3$$

$$\text{For } k = -1, AP = \sqrt{(2+2)^2 + (2+1)^2} = \sqrt{16+9} = \sqrt{25} = 5 \text{ units}$$

$$\begin{aligned} \text{For } k = -3, AP &= \sqrt{(2+2)^2 + (2+3)^2} \\ &= \sqrt{16+25} = \sqrt{41} = 6.40 \text{ units (approx.)} \end{aligned}$$

34. Since P is equidistant from points A and B

$$\therefore AP = BP \Rightarrow AP^2 = BP^2$$

$$\Rightarrow (k-1-3)^2 + (2-k)^2 = (k-(k-1))^2 + (5-2)^2$$

$$\Rightarrow (k-4)^2 + (2-k)^2 = (1)^2 + (3)^2$$

$$\Rightarrow k^2 + 16 - 8k + 4 + k^2 - 4k = 10$$

$$\Rightarrow 2k^2 - 12k + 20 = 10 \Rightarrow 2k^2 - 12k + 10 = 0$$

$$\Rightarrow k^2 - 6k + 5 = 0 \Rightarrow (k-1)(k-5) = 0 \Rightarrow k = 1, 5$$

35. Let P be (0, y) which is equidistant from A(4, 8) and B(-6, 6).

$$\therefore AP = PB \Rightarrow AP^2 = PB^2$$

$$\Rightarrow (4-0)^2 + (8-y)^2 = (0+6)^2 + (y-6)^2$$

$$\Rightarrow 16 + 64 + y^2 - 16y = 36 + y^2 + 36 - 12y$$

$$\Rightarrow 80 - 16y = 72 - 12y$$

$$\Rightarrow 4y = 8 \Rightarrow y = 2$$

$$\therefore \text{Coordinates of } P = (0, 2)$$

$$\text{Now, } AP = \sqrt{(0-4)^2 + (2-8)^2} = \sqrt{52} = 2\sqrt{13} \text{ units}$$

36.  $\therefore$  O is the mid-point of the base BC,

$\therefore$  Coordinates of point B are (0, 3)

So, BC = 6 units.

Let the coordinates of point A be (x, 0).

$$\therefore AB = \sqrt{(0-x)^2 + (3-0)^2} = \sqrt{x^2+9}$$

Also, AB = BC ( $\because \Delta ABC$  is an equilateral triangle)

$$\Rightarrow \sqrt{x^2+9} = 6 \Rightarrow x^2 + 9 = 36$$

$$\Rightarrow x^2 = 27 \Rightarrow x = \pm 3\sqrt{3}$$

$$\therefore \text{Coordinates of point } A = (x, 0) = (3\sqrt{3}, 0)$$

Since BACD is a rhombus,

$$\therefore AB = AC = CD = DB$$

$$\therefore \text{Coordinates of point } D = (-3\sqrt{3}, 0)$$

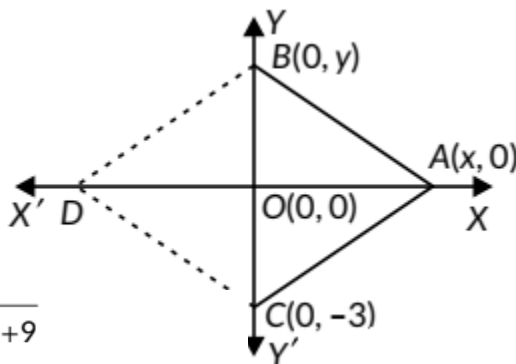

37. The coordinates of Q are  $(-4,0)$ .  
 Since,  $O(0, 0)$  is the mid-point of QR.

$\therefore$  Coordinates of point R are  $(4, 0)$ .

Let coordinates of point P be  $(0, y)$  or  $(0, -y)$

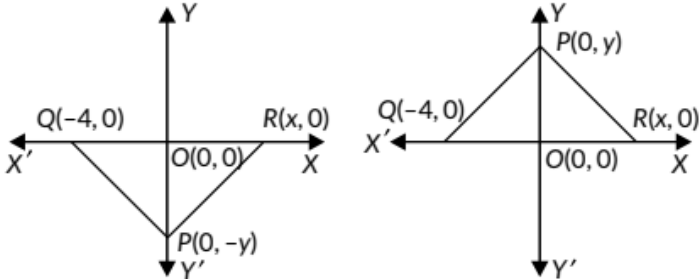

Now,  $PQ = QR$

$$\Rightarrow PQ^2 = QR^2$$

$\Rightarrow$  (A is equilateral)

$$\Rightarrow (-4-0)^2 + (0-y)^2 = (4+4)^2 + (0-0)^2$$

$$\Rightarrow 16 + y^2 = 64 \Rightarrow y^2 = 64 - 16 \Rightarrow y^2 =$$

$$\Rightarrow y = +4\sqrt{3}$$

$\therefore$  The coordinates of point P are  $(0, 4\sqrt{3})$  or  $(0, -4\sqrt{3})$ .

38. (d): Let the point on the x-axis be  $(x, 0)$ , which divides the line segment joining the points  $A(3, 6)$  and  $B(-12, -3)$  in the ratio  $k : 1$ .

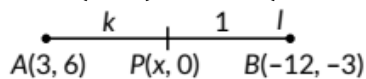

Using section formula, we have

$$(x, 0) = \left( \frac{(-12)k + 3(1)}{k+1}, \frac{(-3)k + 6(1)}{k+1} \right)$$

$$\Rightarrow \frac{-3k+6}{k+1} = 0 \Rightarrow -3k+6=0 \Rightarrow k=2$$

Hence, the required ratio is 2: 1.

39. (c): Let point P(-4, 6) divides the line segment AB in the ratio  $m_1 : m_2$ .

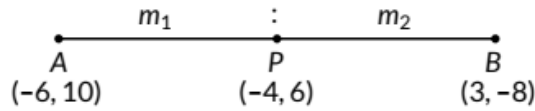

By section formula, we have

$$(-4, 6) = \left( \frac{3m_1 - 6m_2}{m_1 + m_2}, \frac{-8m_1 + 10m_2}{m_1 + m_2} \right)$$

$$\text{Now, } -4 = \frac{3m_1 - 6m_2}{m_1 + m_2}$$

$$\Rightarrow 3m_1 - 6m_2 = -4m_1 - 4m_2 \Rightarrow 7m_1 = 2m_2 \therefore m_1 : m_2 = 2 : 7$$

Putting the value of  $m_1 : m_2$  in y-coordinate, we get

$$\frac{-8\frac{m_1}{m_2} + 10}{\frac{m_1}{m_2} + 1} = \frac{-8 \times \frac{2}{7} + 10}{\frac{2}{7} + 1} = 6$$

Hence, required ratio is 2 : 7.

40. (c): Coordinates of S are (-6, 4).

41. (b): Coordinates of D are (-2, -4) and coordinates of H are (8, 2).

$$\therefore \text{Mid point of } DH = \left( \frac{-2+8}{2}, \frac{-4+2}{2} \right) = (3, -1)$$

42. (d): Coordinates of A are (-2, 4) and coordinates of C are (4, -4).

Let (x, 0) divides the line segment joining the points A and C in the ratio  $m_1 : m_2$ .

By section formula, we have

$$(x, 0) = \left( \frac{4m_1 - 2m_2}{m_1 + m_2}, \frac{-4m_1 + 4m_2}{m_1 + m_2} \right)$$

$$\text{Now, } 0 = \frac{-4m_1 + 4m_2}{m_1 + m_2}$$

$$\Rightarrow -4m_1 + 4m_2 = 0$$

$$\Rightarrow m_1 : m_2 = 1 : 1$$

43. (c): Coordinates of P are (-6, -4) and coordinates of Q are (8, 6).

$$\begin{aligned} \therefore PQ &= \sqrt{(8+6)^2 + (6+4)^2} && \text{[By distance formula]} \\ &= \sqrt{196+100} = 2\sqrt{74} \text{ units} \end{aligned}$$

44. (b): Coordinates of vertices of rectangle IJKL are respectively I(2, -2), J(2, -6), K(8, -6), L(8,-2).

45. I. (d): From figure coordinates are A(2, 5), B(5, 7), C(8,6) and D(6, 3).

$$\text{Now, } AB = \sqrt{(2-5)^2 + (5-7)^2} = \sqrt{9+4} = \sqrt{13} \text{ units}$$

$$BC = \sqrt{(5-8)^2 + (7-6)^2} = \sqrt{9+1} = \sqrt{10} \text{ units}$$

$$CD = \sqrt{(8-6)^2 + (6-3)^2} = \sqrt{4+9} = \sqrt{13} \text{ units}$$

$$DA = \sqrt{(6-2)^2 + (3-5)^2} = \sqrt{16+4} = \sqrt{20} \text{ units}$$

Clearly, ABCD is a quadrilateral

II. (a): Here, sports teacher is at O(0, 0).

$$\text{Now, } OA = \sqrt{2^2 + 5^2} = \sqrt{29} = 5.3 \text{ units}$$

$$OB = \sqrt{5^2 + 7^2} = \sqrt{74} = 8.6 \text{ units}$$

$$OC = \sqrt{8^2 + 6^2} = \sqrt{100} = 10 \text{ units}$$

$$OD = \sqrt{6^2 + 3^2} = \sqrt{45} = 6.7 \text{ units}$$

∴ OA is the minimum distance

∴ A is closest to sports teacher.

III. (a): Required distance,  $AC = \sqrt{(8-2)^2 + (6-5)^2}$   
 $= \sqrt{(6)^2 + (1)^2} = \sqrt{36+1} = \sqrt{37} \text{ units}$

IV. (c): Coordinates of mid-point of AC are

$$\left( \frac{2+8}{2}, \frac{5+6}{2} \right) = \left( \frac{10}{2}, \frac{11}{2} \right) = \left( 5, \frac{11}{2} \right)$$

V. (b): Let point P(x, y) divides the line segment AD in the ration 1 : 2.

$$\begin{array}{c}
 \text{1 : 2} \\
 \text{A(2, 5) \quad P(x, y) \quad D(6, 3)} \\
 \therefore x = \frac{1(6)+2(2)}{1+2}, y = \frac{1(3)+2(5)}{1+2} \\
 \Rightarrow x = \frac{6+4}{3}, y = \frac{3+10}{3} \Rightarrow x = \frac{10}{3}, y = \frac{13}{3} \\
 \therefore \text{Coordinates of P are } \left(\frac{10}{3}, \frac{13}{3}\right)
 \end{array}$$

46. (d): Let coordinates of the point on the x-axis be P(x, 0). Let the given points be A(-4, 0) and B(10, 0), which also lie on x-axis. Since P is equidistant from A and B.

$$\therefore x = \frac{-4+10}{2} = \frac{6}{2} = 3$$

So, P(3, 0) is equidistant from A(-4, 0) and B(10, 0).

47. (d) Since, the point P(k, 0) divides the line segment joining A(2,-2) and B(-7, 4) in the ratio 1 : 2.

$$\begin{array}{c}
 \text{1 \quad P(k, 0) \quad 2} \\
 \text{A(2, -2) \quad B(-7, 4)} \\
 \therefore k = \frac{1(-7)+2(2)}{1+2} = \frac{-7+4}{3} = \frac{-3}{3} = -1
 \end{array}$$

48. (c): Let the coordinates of centre of the circle be (x, y) and AB be the given diameter.

:- By using mid-point formula,

$$\text{we have } x = \frac{-6+6}{2} = 0, y = \frac{3+4}{2} = \frac{7}{2}$$

$$\therefore \text{Coordinates of C are } \left(0, \frac{7}{2}\right)$$

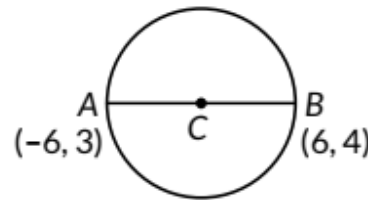

49. Let coordinates of the point A be (x, y) and O is the mid point of AB. By using mid-point formula, we have

$$-2 = \frac{x+3}{2} \text{ and } 2 = \frac{y+4}{2}$$

$$\Rightarrow -4 = x + 3 \text{ and } 4 = y + 4$$

$$\Rightarrow x = -7 \text{ and } y = 0$$

$$\therefore \text{Coordinates of A are } (-7, 0).$$

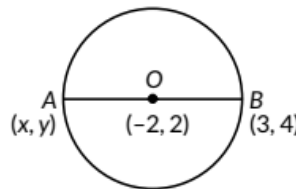

50. Let the point  $R(x, 0)$  on x-axis divides the line segment  $PQ$  in the ratio  $k:1$ .

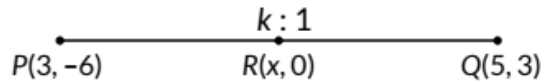

$\therefore$  By section formula, we have

$$\frac{k(3)+1(-6)}{k+1}=0 \Rightarrow 3k-6=0 \Rightarrow k=2$$

$\therefore$  Required ratio is  $2:1$ .

51. Let the point  $P(x, 0)$  divides the segment joining the points  $A(1, -3)$  and  $B(4, 5)$  in the ratio  $k:1$ .

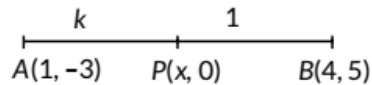

Coordinates of  $P$  are  $\left(\frac{4k+1}{k+1}, \frac{5k-3}{k+1}\right)$  [By Section Formula]

Since, y-coordinate of  $P$  is 0.

$$\therefore \frac{5k-3}{k+1}=0 \Rightarrow 5k=3 \Rightarrow k=\frac{3}{5}$$

Hence, the point  $P$  divides the line segment in the ratio  $3:5$ .

$$\text{Also, x-coordinate of } P = \frac{4k+1}{k+1} = \frac{4\left(\frac{3}{5}\right)+1}{\frac{3}{5}+1} = \frac{\frac{17}{5}}{\frac{8}{5}} = \frac{17}{8}$$

$\therefore$  Coordinates of point  $P$  are  $\left(\frac{17}{8}, 0\right)$ .

53. Let the coordinates of  $A$  be  $(x, y)$ .

Here,  $O(3, 1)$  is the mid point of  $AB$ .

$\therefore$  By using mid point formula, we have

$$\frac{x+2}{2}=3, \frac{y+6}{2}=-1$$

$$\Rightarrow x=4, y=-8$$

$\therefore$  Coordinates of  $A$  are  $(4, -8)$ .

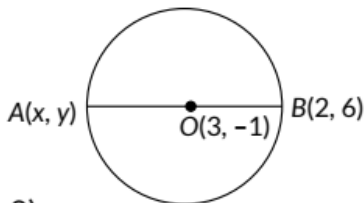

54. The given points are A(2, 3) and B(6, -3). Let the point P(4, m) divides the line segment AB in the ratio k : 1.

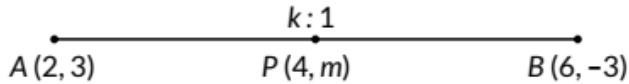

Using the section formula, we have

$$(4, m) = \left( \frac{6k+2}{k+1}, \frac{-3k+3}{k+1} \right) \Rightarrow \frac{6k+2}{k+1} = 4$$

$$\Rightarrow 6k + 2 = 4k + 4 \Rightarrow 2k = 2 \Rightarrow k = 1$$

Thus, the required ratio is 1 : 1.

$$\text{Now, } \frac{-3k+3}{k+1} = m \Rightarrow \frac{-3 \times 1 + 3}{1+1} = m \Rightarrow m = 0$$

55. Let coordinates of P and Q be (0, y) and (x, 0) respectively. Let M(2,5) be the mid-point of PQ.

$$\therefore \text{ By mid point formula } M(x,y) = \left( \frac{x_1+x_2}{2}, \frac{y_1+y_2}{2} \right),$$

$$2 = \frac{x+0}{2}, -5 = \frac{0+y}{2}$$

$$\Rightarrow x = 4, y = -10$$

$\therefore$  Points are P(0, -10) and Q(4, 0).

56. Let the point P(0, y) on y-axis divides the line segment AB in the ratio k : 1.

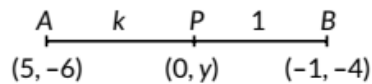

$$\therefore \text{ By section formula, } \frac{-k+5}{k+1} = 0 \Rightarrow k = 5 \quad \dots(i)$$

$$\text{and } \frac{-4k-6}{k+1} = y \Rightarrow \frac{-4(5)-6}{5+1} = y \quad (\text{Using (i)})$$

$$\Rightarrow y = \frac{-26}{6} = \frac{-13}{3}$$

Hence, the required point is  $\left( 0, -\frac{13}{3} \right)$  and required ratio is 5 : 1.

57. Let  $(X_1, Y_1)$  and  $(x_2, y_2)$  be coordinates of P and Q respectively.

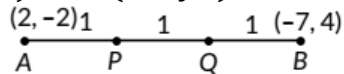

i.e., Q divides AB in ratio 2 : 1.

$$\therefore x_2 = \frac{(2 \times (-7)) + (1 \times 2)}{2+1} \Rightarrow x_2 = \frac{-14+2}{3} = \frac{-12}{3} = -4$$

$$\text{and } y_2 = \frac{(2 \times 4) + (1 \times (-2))}{2+1} = \frac{8-2}{3} = \frac{6}{3} = 2$$

$$\therefore Q(x_2, y_2) = (-4, 2)$$

Now, mid-point of AQ is P.

$$\text{So, } x_1 = \frac{2+(-4)}{2} = \frac{-2}{2} = -1 \text{ and } y_1 = \frac{-2+2}{2} = 0$$

$$\therefore P(x_1, y_1) = (-1, 0)$$

58. Let the point  $(-3, k)$  divides the line segment joining the points  $(-5, -4)$  and  $(-2, 3)$  in the ratio  $\lambda : 1$ .

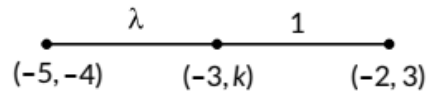

$$\therefore -3 = \frac{-2\lambda - 5}{\lambda + 1} \quad \dots(i)$$

$$\text{and } k = \frac{3\lambda - 4}{\lambda + 1} \quad \dots(ii)$$

$$\text{From (i), } -3\lambda - 3 = -2\lambda - 5 \Rightarrow \lambda = 2$$

$$\text{Using } \lambda = 2 \text{ in (ii), we get } k = \frac{3(2) - 4}{2 + 1} = \frac{2}{3}$$

Hence, required ratio is 2 : 1 and  $k = \frac{2}{3}$ .

59.

Let  $P\left(\frac{3}{4}, \frac{5}{12}\right)$  divides  $AB$  internally in the ratio  $k : 1$ .

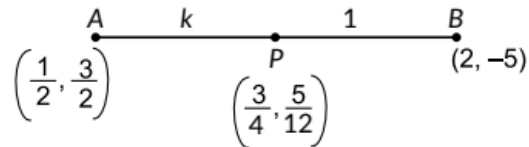

Using section formula, we have

$$\frac{2k + \frac{1}{2}}{k + 1} = \frac{3}{4} \Rightarrow 8k + 2 = 3k + 3$$

$$\Rightarrow 8k - 3k = 3 - 2 \Rightarrow 5k = 1 \text{ or } k = \frac{1}{5}$$

$\therefore$  Required ratio is 1 : 5.

60. Let the point  $P(0, y)$  on  $y$ -axis divides the line segment joining the points  $A(6, -4)$  and  $B(-2, -7)$  in the ratio  $k : 1$ .

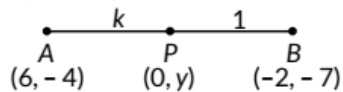

$\therefore$  By section formula, we have  $\frac{-2k + 6}{k + 1} = 0$

$$\Rightarrow -2k + 6 = 0 \Rightarrow k = 3 \qquad \dots(i)$$

and  $\frac{-7k - 4}{k + 1} = y \Rightarrow \frac{-7(3) - 4}{3 + 1} = y$  [Using (i)]

$$\Rightarrow 4y = -21 - 4 = -25 \Rightarrow y = \frac{-25}{4}$$

Hence, the required point is  $\left(0, \frac{-25}{4}\right)$  and required ratio is 3 : 1.

61. We have,  $A(2, 5)$ ,  $B(x, y)$  and  $C(-1, 2)$  and point  $C$  divides  $AB$  in the ratio 3 : 4.

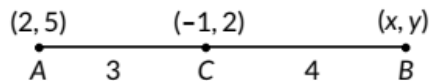

$$\therefore -1 = \frac{3x + 8}{7} \Rightarrow -7 = 3x + 8 \Rightarrow x = \frac{-15}{3} = -5$$

and  $2 = \frac{3y + 20}{7} \Rightarrow 14 = 3y + 20 \Rightarrow y = \frac{-6}{3} = -2$

$\therefore$  Coordinates of  $B = (-5, -2)$

62.

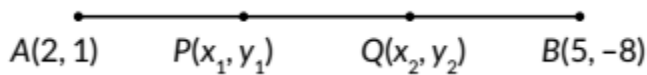

Let  $P(x_1, y_1)$  and  $Q(x_2, y_2)$  are the points of trisection of line segment AB.

$\therefore AP = PQ = QB$

Now, point P divides AB internally in the ratio 1: 2.

$\therefore$  By section formula, we have

$$x_1 = \frac{1 \times 5 + 2 \times 2}{1 + 2}, y_1 = \frac{1 \times (-8) + 2(1)}{1 + 2}$$

$$\Rightarrow x_1 = \frac{9}{3}, y_1 = \frac{-6}{3} \Rightarrow x_1 = 3, y_1 = -2$$

Since, point  $P(3, -2)$  lies on the line  $2x - y + k = 0$ .

$$\therefore 6 + 2 + k = 0 \Rightarrow k = -8$$

63. Let point  $P(x_1, Y_1)$  divides the line segment joining the points  $A(-2, -5)$  and  $B(6, 3)$  in the ratio  $k: 1$ .

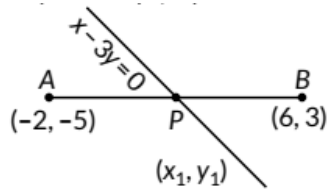

$\therefore$  Coordinates of P are

$$(x_1, y_1) = \left( \frac{k(6) + 1(-2)}{k + 1}, \frac{k(3) + 1(-5)}{k + 1} \right) = \left( \frac{6k - 2}{k + 1}, \frac{3k - 5}{k + 1} \right)$$

The point P lies on line  $x - 3y = 0$

$$\therefore \frac{6k - 2}{k + 1} - 3 \left( \frac{3k - 5}{k + 1} \right) = 0 \Rightarrow 6k - 2 - 3(3k - 5) = 0$$

$$\Rightarrow 6k - 2 - 9k + 15 = 0 \Rightarrow -3k = -13 \Rightarrow k = \frac{13}{3}$$

$\therefore$  Required ratio is 13 : 3.

$$\text{Now, coordinates of } P \text{ are } \left( \frac{6 \left( \frac{13}{3} \right) - 2}{\frac{13}{3} + 1}, \frac{3 \left( \frac{13}{3} \right) - 5}{\frac{13}{3} + 1} \right) = \left( \frac{9}{2}, \frac{3}{2} \right)$$

64. Let the point  $P(-4, y)$  divides the line segment joining the points A and B in the ratio  $k: 1$ .

$$\begin{array}{c} A \quad k \quad P \quad 1 \quad B \\ (-6, 10) \quad (-4, y) \quad (3, -8) \end{array}$$

∴ By section formula, coordinates of P are

$$(-4, y) = \left( \frac{k(3) + 1(-6)}{k+1}, \frac{k(-8) + 1(10)}{k+1} \right)$$

$$\Rightarrow \frac{3k-6}{k+1} = -4 \Rightarrow 3k-6 = -4k-4 \Rightarrow 7k=2 \Rightarrow k = \frac{2}{7}$$

∴ Required ratio is 2 : 7.

$$\text{Now, } y = \frac{-8k+10}{k+1} = \frac{-8\left(\frac{2}{7}\right)+10}{\frac{2}{7}+1} = 6.$$

65. Let the given points are A(-2, 1), B(a, 0), C(4, b) and D(1, 2)

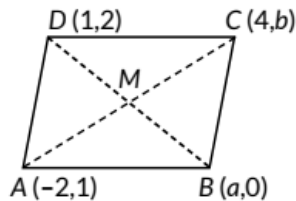

Let co-ordinates of M are (x, y).

∴ Co-ordinates of M are given by

$$x = \frac{4-2}{2} = \frac{1+a}{2} \Rightarrow 1+a=2 \Rightarrow a=1$$

$$y = \frac{b+1}{2} = \frac{2+0}{2} \Rightarrow b+1=2 \Rightarrow b=1$$

Hence,  $a = 1, b = 1$

Now,  $AB = CD$  and  $BC = AD$

(∵ Opposite sides of a parallelogram are equal)

$$\therefore AB = CD = \sqrt{(-2-1)^2 + (1-0)^2} = \sqrt{9+1} = \sqrt{10} \text{ units}$$

$$\text{and } BC = AD = \sqrt{(1-4)^2 + (0-1)^2} = \sqrt{9+1} = \sqrt{10} \text{ units.}$$

66.

Let  $R\left(\frac{24}{11}, y\right)$  divides the line segment joining the points  $P(2, -2)$  and  $Q(3, 7)$  in the ratio  $k : 1$ .

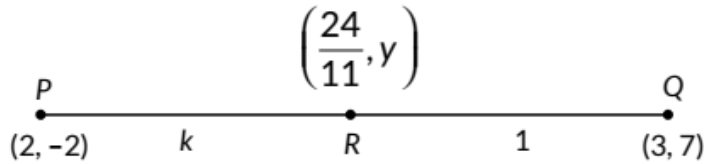

$$\therefore \frac{24}{11} = \frac{2+3k}{k+1} \quad \dots(i) \quad \text{and} \quad y = \frac{-2+7k}{k+1} \quad \dots(ii)$$

$$\text{From (i), } 24(k+1) = 11(2+3k) \Rightarrow 24k + 24 = 22 + 33k$$

$$\Rightarrow 9k = 2 \Rightarrow k = \frac{2}{9}$$

$$\text{Putting } k = \frac{2}{9} \text{ in (ii), we get } y = \frac{-2+7\left(\frac{2}{9}\right)}{\frac{2}{9}+1}$$

$$\Rightarrow y = \frac{-18+14}{2+9} = \frac{-4}{11}$$

$$\therefore \text{ Required ratio is } 2 : 9 \text{ and value of } y \text{ is } \frac{-4}{11}.$$

67. We have,  $A(2, 5)$ ,  $B(x, y)$  and  $C(-1, 2)$  and point C divides AB in the ratio 3:4.

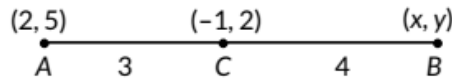

$$\therefore -1 = \frac{3x+8}{7} \Rightarrow -7 = 3x+8 \Rightarrow x = \frac{-15}{3} = -5$$

$$\text{and } 2 = \frac{3y+20}{7} \Rightarrow 14 = 3y+20 \Rightarrow y = \frac{-6}{3} = -2$$

$$\therefore x^2 + y^2 = (-5)^2 + (-2)^2 = 25 + 4 = 29$$

68.

$$\text{We have, } AP = \frac{3}{7} AB \Rightarrow \frac{AB}{AP} = \frac{7}{3}$$

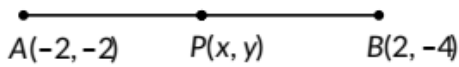

$$\Rightarrow \frac{AB}{AP} - 1 = \frac{7}{3} - 1 \Rightarrow \frac{AB - AP}{AP} = \frac{7 - 3}{3} \Rightarrow \frac{BP}{AP} = \frac{4}{3} \Rightarrow \frac{AP}{BP} = \frac{3}{4}$$

Let  $P(x, y)$  be the point which divides  $AB$  in the ratio  $3 : 4$ .

$\therefore$  By section formula,

$$x = \frac{3(2) + 4(-2)}{3 + 4} = \frac{6 - 8}{7} = \frac{-2}{7}$$

$$y = \frac{3 \times (-4) + 4 \times (-2)}{3 + 4} = \frac{-12 - 8}{7} = \frac{-20}{7}$$

Thus,  $P(x, y)$  is  $\left(\frac{-2}{7}, \frac{-20}{7}\right)$

69.

$$\text{We have, } AP = \frac{2}{5} AB$$

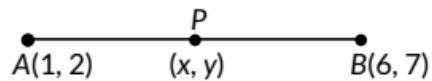

$$\Rightarrow \frac{AB}{AP} = \frac{5}{2} \Rightarrow \frac{AP + PB}{AP} = \frac{5}{2}$$

$$\Rightarrow 1 + \frac{PB}{AP} = \frac{5}{2} \Rightarrow \frac{PB}{AP} = \frac{5}{2} - 1 = \frac{3}{2}$$

$$\Rightarrow AP : PB = 2 : 3 \Rightarrow m_1 : m_2 = 2 : 3$$

Let  $P(x, y)$  be the point which divides the line joining  $A(1, 2)$  and  $B(6, 7)$  in the ratio  $2 : 3$ .

$$\text{Thus, } x = \frac{2 \times 6 + 3 \times 1}{2 + 3} = \frac{12 + 3}{5} = 3$$

$$\text{and } y = \frac{2 \times 7 + 3 \times 2}{2 + 3} = \frac{14 + 6}{5} = 4$$

So, the coordinates of point  $P$  are  $(3, 4)$ .

70. Point P(6, -6) lies on the line  $3x + k(y + 1) = 0$

$$\therefore 3(6) + k(-6 + 1) = 0 \Rightarrow 18 - 5k = 0 \Rightarrow k = \frac{18}{5}$$

71. Let point P(x, 0) divides the line segment joining the points A and B in the ratio k: 1.

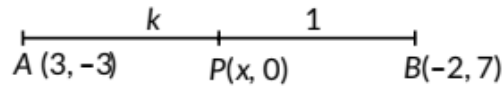

Using section formula,

$$\text{coordinates of } P \text{ are } \left( \frac{-2k+3}{k+1}, \frac{7k-3}{k+1} \right)$$

$$y\text{-coordinate of } P = \frac{7k-3}{k+1} = 0 \Rightarrow 7k = 3 \Rightarrow k = \frac{3}{7}$$

Hence, the point P divides the line segment in the ratio 3: 7.

$$\text{Also, } x\text{-coordinate of } P = \frac{-2k+3}{k+1} = \frac{-6+21}{10} \quad \left[ \because k = \frac{3}{7} \right]$$

$$\Rightarrow x = \frac{15}{10} = 1.5$$

$\therefore$  Coordinates of point P are (1.5, 0).

72. ABCD is a rectangle. AC and BD are its diagonals.

To prove : AC = BD

and AC bisects BD or vice versa.

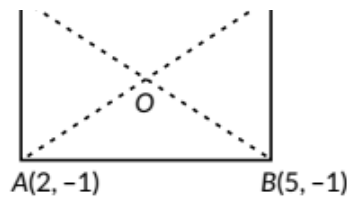

$$\text{Now, } AC = \sqrt{(5-2)^2 + (6+1)^2} = \sqrt{(3)^2 + (7)^2} = \sqrt{58} \text{ units}$$

$$\text{and } BD = \sqrt{(5-2)^2 + (-1-6)^2} = \sqrt{(3)^2 + (-7)^2} = \sqrt{58} \text{ units}$$

$$\Rightarrow AC = BD$$

Let us assume that O is the mid-point of both AC and BD.

$$\text{Coordinates of } O \text{ from } AC = \left( \frac{2+5}{2}, \frac{-1+6}{2} \right) = \left( \frac{7}{2}, \frac{5}{2} \right)$$

$$\text{Coordinates of } O \text{ from } BD = \left( \frac{5+2}{2}, \frac{-1+6}{2} \right) = \left( \frac{7}{2}, \frac{5}{2} \right)$$

$\Rightarrow$  AC and BD bisect each other at O.

73. Since, P, Q, R and S divides the line segment joining the points A(1, 2) and B(6, 7) in 5 equal parts.



∴ P divides AB in ratio 1 : 4.

Let coordinates of P be (x, y).

Using section formula, coordinate of P are given by

$$\left( \frac{mx_2 + nx_1}{m+n}, \frac{my_2 + ny_1}{m+n} \right)$$

$$\therefore x = \frac{1(6) + 4(1)}{1+4} = \frac{10}{5} = 2; \quad y = \frac{1(7) + 4(2)}{1+4} = \frac{15}{5} = 3$$

$$\therefore P(x, y) = (2, 3)$$

Let coordinates of Q be (x<sub>1</sub>, y<sub>1</sub>).

Since, Q divides AB in ratio 2 : 3.

$$\therefore x_1 = \frac{2(6) + 3(1)}{2+3} = \frac{15}{5} = 3; \quad y_1 = \frac{2(7) + 3(2)}{2+3} = \frac{20}{5} = 4$$

$$\therefore Q(x_1, y_1) = (3, 4)$$

Let coordinates of R be (x<sub>2</sub>, y<sub>2</sub>).

Since, R divides AB in ratio 3 : 2.

$$\therefore x_2 = \frac{3(6) + 2(1)}{2+3} = \frac{20}{5} = 4 \text{ and } y_2 = \frac{3(7) + 2(2)}{2+3} = \frac{25}{5} = 5$$

$$\therefore R(x_2, y_2) = (4, 5)$$

74. (i) We have, P = (-200, 0) and Q = (200, 0)

The coordinates of R and S are (200, 400) and (-200, 400).

(ii) (a) The length PQ = 200 + 200  
= 400 units.

Area of square PQRS = 400 x 400  
= 160000 sq. units.

**OR**

(b) Length of diagonal PR =  $\sqrt{2} \times$  length of side  
=  $400\sqrt{2}$  units.

(iii)

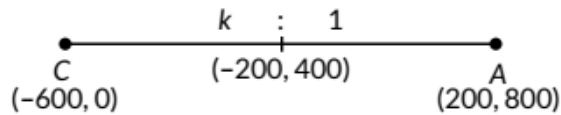

Using section formula, we have

$$(-200, 400) = \left( \frac{(200)k + (-600)1}{k+1}, \frac{(800)k + (0)1}{k+1} \right)$$

$$\Rightarrow 400 = \frac{800k}{k+1}$$

$$\Rightarrow k + 1 = 2k \Rightarrow k = 1$$

75. Let the point P(x, 2) divides the line segment joining the points A(12, 5) and B(4, -3) in the ratio k : 1.

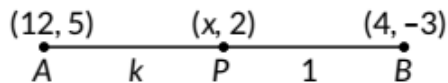

Then, the coordinates of P are  $\left( \frac{4k+12}{k+1}, \frac{-3k+5}{k+1} \right)$

Now, the coordinates of P are (x, 2).

$$\therefore \frac{4k+12}{k+1} = x \text{ and } \frac{-3k+5}{k+1} = 2$$

$$\Rightarrow -3k + 5 = 2k + 2 \Rightarrow 5k = 3 \Rightarrow k = 3/5$$

Substituting  $k = \frac{3}{5}$  in  $\frac{4k+12}{k+1} = x$ , we get

$$x = \frac{4 \times \frac{3}{5} + 12}{\frac{3}{5} + 1} = \frac{12 + 60}{3 + 5} = \frac{72}{8} = 9$$

Thus, the value of x is 9.

Also, the point P divides the line segment joining the points A(12, 5) and B(4, -3) in the ratio 3: 5.

76

Let coordinates of  $P$  be  $(x_1, y_1)$ .

$\therefore P$  is mid point of  $AB$ .

$$\therefore x_1 = \frac{-10-2}{2} \text{ and } y_1 = \frac{4+0}{2}$$

$$\Rightarrow x_1 = -6 \text{ and } y_1 = 2$$

$$\therefore P(x_1, y_1) = (-6, 2)$$

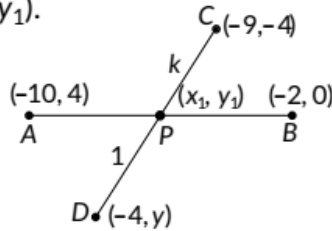

Let  $P(-6, 2)$  divides  $CD$  in ratio  $k : 1$ .

$$\therefore -6 = \frac{-4k-9}{k+1} \dots(i) \text{ and } 2 = \frac{ky-4}{k+1} \dots(ii)$$

From (i), we have,  $4k + 9 = 6k + 6$

$$\Rightarrow 3 = 2k \Rightarrow k = 3/2$$

Hence  $P$  divides  $CD$  in ratio  $3 : 2$ .

$$\text{From (ii), } 2(k + 1) = ky - 4 \Rightarrow 2k + 6 = ky$$

$$\Rightarrow 3+6 = \frac{3}{2}y \quad \left[ \because k = \frac{3}{2} \right]$$

$$\Rightarrow y = 6$$

### CBSE Sample Questions

1.

(a): Length of  $DE = \sqrt{(3+3)^2 + (5+3)^2} = \sqrt{6^2 + 8^2}$   
 $= 10$  units

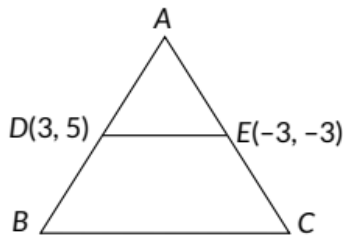

We know, line joining the mid points of two sides of a triangle is parallel to third side and equal to half of it.

$$\text{So, } DE = \frac{1}{2}BC \Rightarrow BC = 20 \text{ units.}$$

We know, line joining the mid points of two sides of a triangle is parallel to third side and equal to half of it.

2. (d): Distance of point  $A(-5, 6)$  from the origin

$$(0, 0) \text{ is } \sqrt{(0+5)^2 + (0-6)^2} = \sqrt{25+36} = \sqrt{61} \text{ units} \quad (1)$$

3. (d): Any point P(x, y) of perpendicular bisector will be equidistant from A and B.

$$\therefore \sqrt{(x-4)^2 + (y-5)^2} = \sqrt{(x+2)^2 + (y-3)^2}$$

$$\begin{aligned} &= x^2 + 16 - 8x + y^2 + 25 - 10y = x^2 + 4 + 4x + y^2 + 9 - 6y \\ &= -12x - 4y + 28 - 03x + y - 7 = 0 \quad (1) \end{aligned}$$

4. Let P(x, 0) be the point on x-axis which is equidistant from A(2, -2) and B(-4, 2).

Thus, PA = PB (1/2)

$$\Rightarrow PA^2 = PB^2 \quad (1/2)$$

$$\Rightarrow (x - 2)^2 + (0 + 2)^2 = (x + 4)^2 + (0 - 2)^2$$

$$\Rightarrow x^2 + 4 - 4x + 4 = x^2 + 16 + 8x + 4$$

$$\Rightarrow 4 - 4x = 8x + 16 \Rightarrow x = -1 \quad (1/2)$$

$$\Rightarrow P = (-1, 0) \quad (1/2)$$

5. (c): Let coordinates of S is (h, k).

Diagonals of parallelogram bisect each other.

$$\therefore \left( \frac{-3+3}{2}, \frac{-2+4}{2} \right) \equiv \left( \frac{h-2}{2}, \frac{k+3}{2} \right)$$

$$\Rightarrow (0, 1) \equiv \left( \frac{h-2}{2}, \frac{k+3}{2} \right)$$

$$\therefore h = 2 \text{ and } k = -1$$

So, the coordinates of S is (2, -1).

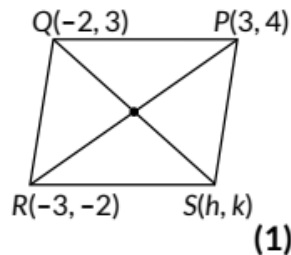

6. (a): Since, ABCD is a parallelogram, diagonals AC and BD bisect each other.

∴ Mid point of AC = Mid point of BD

$$\Rightarrow \left( \frac{x+1}{2}, \frac{6+2}{2} \right) = \left( \frac{3+4}{2}, \frac{5+y}{2} \right)$$

Comparing the co-ordinates, we get

$$\frac{x+1}{2} = \frac{3+4}{2} \Rightarrow x = 6$$

$$\text{Similarly, } \frac{6+2}{2} = \frac{5+y}{2} \Rightarrow y = 3$$

$$\therefore (x, y) = (6, 3)$$

7. (a): Since, P divides the line segment joining R(-1,3) and S(9,8) in the ratio k: 1.

$$\therefore \text{Coordinates of } P \text{ are } \left( \frac{9k-1}{k+1}, \frac{8k+3}{k+1} \right)$$

Since, P lies on the line  $x - y + 2 = 0$ , then

$$\begin{aligned} \frac{9k-1}{k+1} - \frac{8k+3}{k+1} + 2 &= 0 \\ \Rightarrow 9k - 1 - 8k - 3 + 2k + 2 &= 0 \Rightarrow k = \frac{2}{3} \end{aligned} \quad (1)$$

8. (a): We have, coordinates of E, H and J are (2, 1), (-2, 4) and (-2,-2) respectively.

∴ Centroid of AEHJ

$$= \left( \frac{2-2-2}{3}, \frac{1+4-2}{3} \right) = \left( \frac{-2}{3}, 1 \right) \quad (1)$$

9. (c): If P needs to be at equal distance from A(3, 6) and G(1,-3) such that A, P and G are collinear, then P will be the midpoint of AG.

$$\text{So, coordinates of } P = \left( \frac{3+1}{2}, \frac{6-3}{2} \right) = \left( 2, \frac{3}{2} \right) \quad (1)$$

10. (a): Let the point on x-axis which is equidistant from (-1, 1) and E(2, 1) be (x, 0).

$$\therefore \sqrt{(x+1)^2 + (0-1)^2} = \sqrt{(x-2)^2 + (0-1)^2}$$

$$\Rightarrow x^2 + 1 + 2x + 1 = x^2 + 4 - 4x + 1$$

$$\Rightarrow 6x = 3 \Rightarrow x = 1/2$$

$$\therefore \text{The required point is } \left( \frac{1}{2}, 0 \right). \quad (1)$$

11. (b): Let the coordinates of the position of a player Q such that his distance from K(-4, 1) is twice his distance from E(2, 1) be Q(x, y).

Then  $KQ : QE = 2 : 1$

$$\Rightarrow Q(x, y) = \left( \frac{2 \times 2 + 1 \times (-4)}{3}, \frac{2 \times 1 + 1 \times 1}{3} \right) = (0, 1) \quad (1)$$

12. (d): Let the point on y-axis which is equidistant from B(4,3) and C(4, -1)

be  $(0, y)$ .

$$\Rightarrow \sqrt{(4-0)^2 + (3-y)^2} = \sqrt{(4-0)^2 + (y+1)^2}$$

$$\Rightarrow 16 + y^2 + 9 - 6y = 16 + y^2 + 1 + 2y$$

$$\Rightarrow -8y = -8 \Rightarrow y = 1$$

$\therefore$  Required point is  $(0, 1)$ . (1)

13. (i) (c): Mid point of the line segment joining the points

$$J(6, 17) \text{ and } I(9, 16) \text{ is } \left( \frac{6+9}{2}, \frac{17+16}{2} \right) = \left( \frac{15}{2}, \frac{33}{2} \right)$$

(ii) (a): The distance of the point P from y-axis is 4 units.

(iii) (c) Coordinates of A and S are  $(1, 8)$  and  $(17, 8)$  respectively, therefore the distance between the points

$$A \text{ and } S = \sqrt{(17-1)^2 + (8-8)^2} = 16 \text{ units.}$$

(iv) (d): Let  $M(x, y)$  divides line segment joining  $A(1, 8)$  and  $B(5, 10)$  in the ratio  $1 : 3$ .

$$\text{Then, } x = \frac{5(1)+3(1)}{1+3} \text{ and } y = \frac{1(10)+3(8)}{1+3}$$

$$\Rightarrow x = 2, y = 8.5. \text{ So, the required point is } (2.0, 8.5).$$

(v) (b): Let  $L(x, y)$  is equidistant from  $Q(9, 8)$  and  $S(17, 8)$ .

$$\text{Then, } LQ = LS \Rightarrow (LQ)^2 = (LS)^2$$

$$\Rightarrow (9-x)^2 + (8-y)^2 = (17-x)^2 + (8-y)^2$$

$$\Rightarrow 81 + x^2 - 18x = 289 + x^2 - 34x$$

$$\Rightarrow 16x = 208$$

$$\Rightarrow x - 13 = 0 \quad (1 \times 4 = 4)$$

14. Let the coordinates of R be  $(x, y)$ , clearly R divides the line segment joining  $P(-2, 5)$  and  $Q(3, 2)$  in the ratio

$2:1$ . [  $PR = 2QR$  (Given) ]  $(1/2)$

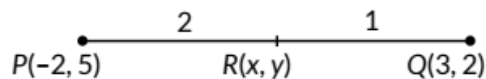

$$\therefore x = \frac{1(-2)+2(3)}{2+1} \text{ and } y = \frac{1(5)+2(2)}{2+1} \quad (1)$$

$$\Rightarrow x = \frac{4}{3} \text{ and } y = 3$$

$$\therefore R = \left( \frac{4}{3}, 3 \right) \quad (1/2)$$

15. (i) From the given figure, B(1, 2), F(-2, 9) The distance between the points B and F is;

$$BF = \sqrt{(-2-1)^2 + (9-2)^2}$$

$$= \sqrt{(-3)^2 + (7)^2} = \sqrt{9+49} = \sqrt{58} \text{ units} \quad (1)$$

(ii) W(-6, 2), X(-4, 0), O(5, 9), P(3, 11)

Clearly, WXOP is a rectangle.

Point of intersection of diagonals of a rectangle is the mid point of the diagonals. So the required point is mid point of WO or XP

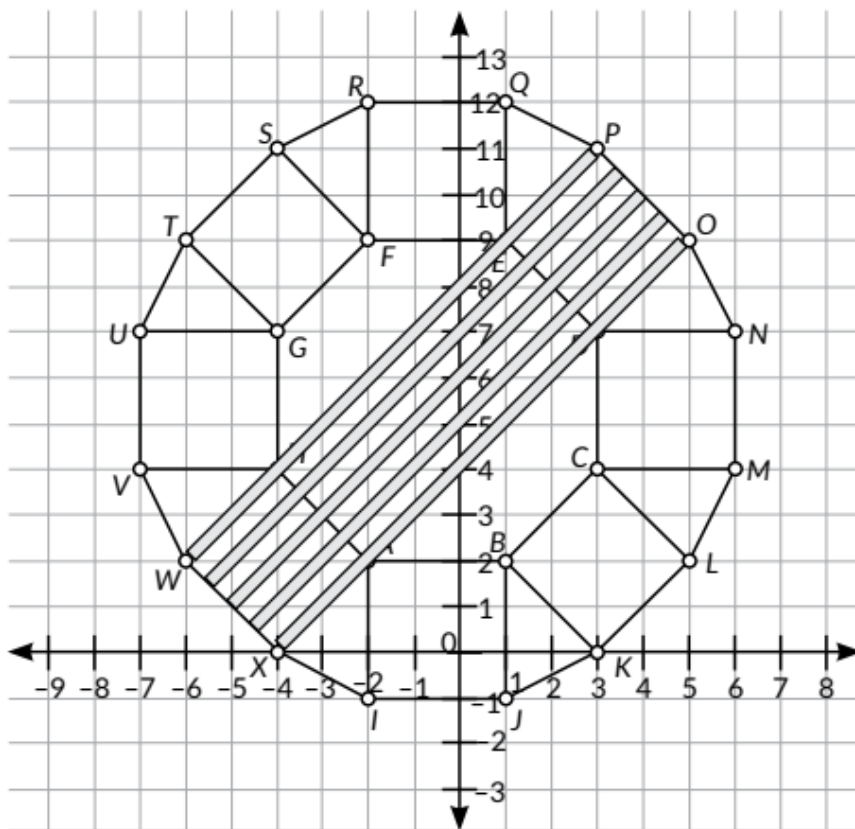

$$= \left( \frac{-6+5}{2}, \frac{2+9}{2} \right) = \left( \frac{-1}{2}, \frac{11}{2} \right) \quad (1)$$

(iii) A(-2, 2), G(-4, 7)

Let the point on y-axis be Z(0, y).

Now, point Z is equidistant from A and G.

$$\therefore AZ^2 = GZ^2 \quad (1/2)$$

$$\Rightarrow (0+2)^2 + (y-2)^2 = (0+4)^2 + (y-7)^2$$

$$\Rightarrow (2)^2 + y^2 + 4 - 4y = (4)^2 + y^2 + 49 - 14y \quad (1/2)$$

$$\Rightarrow 8-4y=65-14y = 10y = 57$$

$$\text{So, } y = 5.7$$

∴ The required point is (0, 5.7) (1)

OR

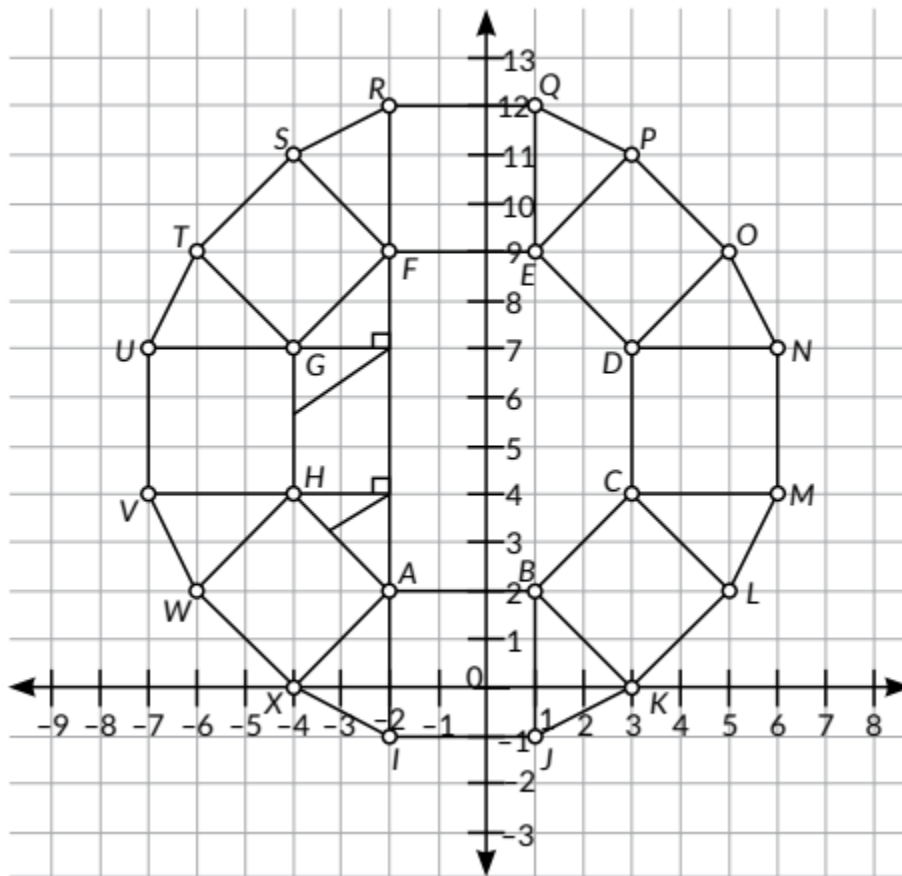

From the given figure,

$$A(-2, 2), F(-2, 9), G(-4, 7), H(-4, 4) \text{ (1/2)}$$

$$\text{Clearly } GH = 7 - 4 = 3 \text{ units}$$

$$AF = 9 - 2 = 7 \text{ units}$$

So, height of the trapezium AFGH = 2 units (1/2)

$$\text{So, area of AFGH} = \frac{1}{2} (AF + GH) \times \text{height}$$

$$= \frac{1}{2} (7 + 3) \times 2$$

$$= 10 \text{ sq. units}$$

(1)