

# Triangles

---

(2025)

1. Which of the following is not the criterion for similarity of triangles ? (1 Mark)

(2025)

- (A) AAA
- (B) SSS
- (C) SAS
- (D) RHS

2. From the figures given below, which of the following is true about the measure of P ? (1 Mark) (2025)

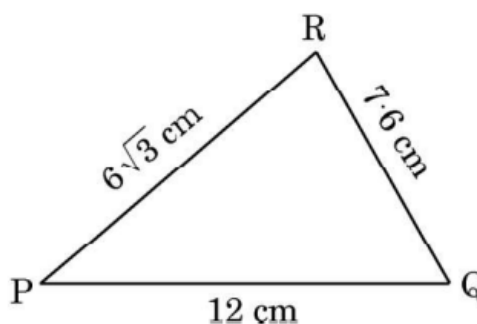
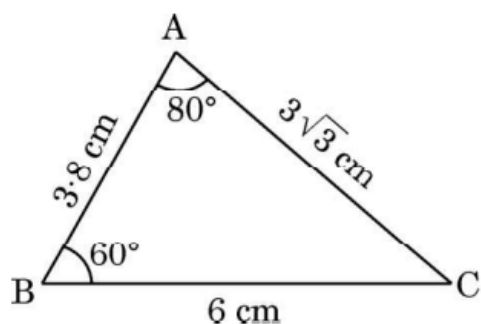

- (A)  $\angle P = 60^\circ$
- (B)  $\angle P = 80^\circ$
- (C)  $\angle P = 40^\circ$
- (D) The measure of P cannot be determined

3. In the given figure, if  $PQ \parallel RS$ , then prove that  $\triangle POQ \sim \triangle SOR$  (2 Mark) (2025)

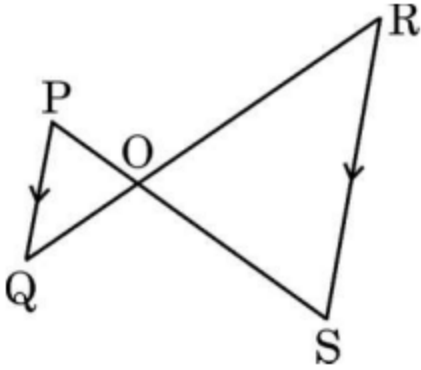

4.

In the given figure,  $\Delta OSR \sim \Delta OQP$ ,  $\angle ROQ = 125^\circ$  and  $\angle ORS = 70^\circ$ . Find the measures of  $\angle OSR$  and  $\angle OQP$ .

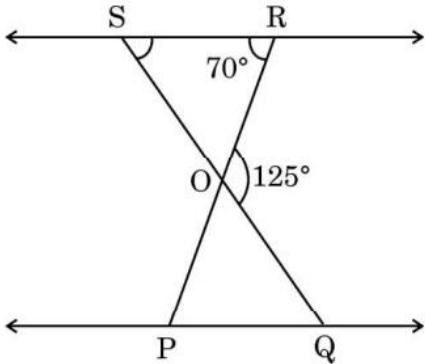

(2 Mark) (2025)

5. State "Basic Proportionality Theorem" and use it to prove the following:

In a quadrilateral ABCD, diagonals AC and BD intersect each other at O (5 Mark) (2025)

such that  $\frac{AO}{BO} = \frac{CO}{DO}$  as shown in the given figure. Prove that ABCD is a trapezium.

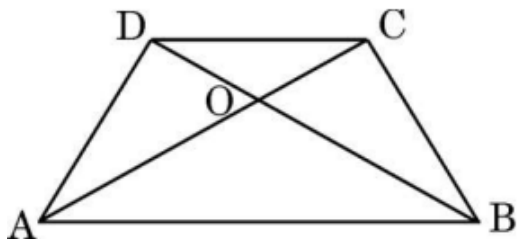

6. In triangles ABC and DEF,  $B = E$ ,  $F = C$  and  $AB = 3 DE$ . Then, the two triangles are : (1 Mark) (2025)

- (A) congruent but not similar
- (B) congruent as well as similar
- (C) neither congruent nor similar
- (D) similar but not congruent

7. (a) If  $\Delta ABC \sim \Delta PQR$  in which  $AB = 6$  cm,  $BC = 4$  cm,  $AC = 8$  cm and  $PR = 6$  cm, then find the length of  $(PQ + QR)$ . (2 Mark) (2025)

8.

In the given figure,  $\frac{QR}{QS} = \frac{QT}{PR}$  and  $\angle 1 = \angle 2$ , show that

$\Delta PQS \sim \Delta TQR$ .

(2 Mark)

(2025)

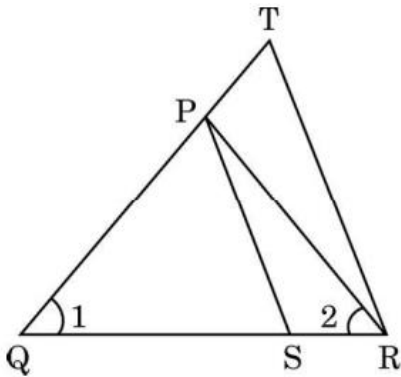

9. (a) The diagonal  $BD$  of a parallelogram  $ABCD$  intersects the line segment  $AE$  at the point  $F$ , where  $E$  is any point on the side  $BC$ . Prove that  $DF \times EF = FB \times FA$ .

(5 Mark) (2025)

10. In  $\Delta ABC$ , if  $AD \perp BC$  and  $AD^2 = BD \times DC$ , then prove that  $\angle BAC = 90^\circ$ . (5 Mark)

(2025)

11. (a) The perimeter of a right triangle is 60 cm and its hypotenuse is 25 cm. Find the lengths of other two sides of the triangle (5 Mark) (2025)

**Answers**

1. (D) RHS

2. (C)  $\angle P = 40^\circ$

3. (a) As  $PQ \parallel RS$

$$\left. \begin{array}{l} \angle P = \angle S \\ \angle Q = \angle R \end{array} \right\} \text{ Alternate interior angles}$$

$\therefore \triangle POQ \sim \triangle SOR$  (by AA similarity criterion)

4.  $\angle OSR = 125^\circ - 70^\circ = 55^\circ$  [ by exterior angle property]

As  $\triangle OSR \sim \triangle OQP$

$\angle OSR = \angle OQP$  (Corresponding angles of similar triangles)

$\angle OQP = 55^\circ$

5. : Statement: If a line is drawn parallel to one side of a triangle to intersect the other two sides in distinct points, the other two sides are divided in the same ratio

Given : ABCD is a quadrilateral in which  $\frac{AO}{BO} = \frac{CO}{DO}$

To Prove :  $AB \parallel CD$

Construction : Draw  $OE \parallel AB$

Proof : In  $\triangle DAB$ ,  $OE \parallel AB$

$$\therefore \frac{DE}{AE} = \frac{DO}{BO} \text{ (by BPT)}$$

$$\text{Also } \frac{AO}{BO} = \frac{CO}{DO} \text{ (given)}$$

$$\Rightarrow \frac{DO}{BO} = \frac{CO}{AO}$$

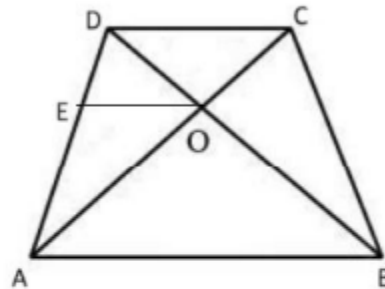

$$\therefore \frac{DE}{AE} = \frac{CO}{AO}$$

In  $\triangle ADC$ ,

$$\frac{DE}{AE} = \frac{CO}{AO}$$

$\therefore OE \parallel CD$  (by converse of BPT)

As  $OE \parallel AB$  and  $OE \parallel CD$

$\therefore AB \parallel CD$

Hence, ABCD is a trapezium

6. (D) similar but not congruent

7.

$$\frac{6}{PQ} = \frac{4}{QR} = \frac{8}{6}$$

$$\Rightarrow PQ = \frac{9}{2} \text{ cm or } 4.5 \text{ cm}$$

and  $QR = 3 \text{ cm}$

$$\therefore PQ + QR = 7.5 \text{ cm}$$

8. In  $\triangle PQR$ ,  $\angle 1 = \angle 2 \therefore PR = PQ$

$$\therefore \frac{QR}{QS} = \frac{QT}{PR} \Rightarrow \frac{QR}{QS} = \frac{QT}{PQ}$$

Also,  $\angle 1 = \angle 1$

$$\therefore \triangle PQS \sim \triangle TQR$$

9.

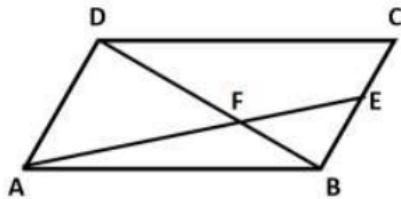

In  $\triangle ADF$  and  $\triangle EBF$ ,

$$\angle DFA = \angle EFB$$

$$\angle ADF = \angle FBE$$

$$\therefore \triangle ADF \sim \triangle EBF$$

$$\therefore \frac{DF}{FB} = \frac{FA}{EF}$$

$$\Rightarrow DF \times EF = FB \times FA$$

10.

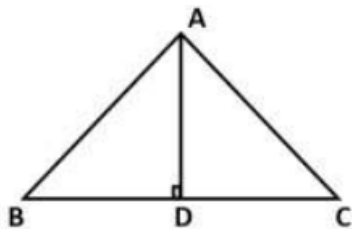

$$AD^2 = BD \times DC$$

$$\frac{AD}{DC} = \frac{BD}{AD}$$

Also,  $\angle ADB = \angle ADC$

$\therefore \triangle DBA \sim \triangle DAC$

$\angle DBA = \angle DAC$

$\angle BAD = \angle DCA$

Adding both

$\angle DBA + \angle DCA = \angle DAC + \angle BAD$

$\therefore \angle BAC = 90^\circ$

**11.** Let the other two sides be  $x$  cm and  $y$  cm

ATQ

$$x + y + 25 = 60$$

$$y = 35 - x$$

Now,

$$x^2 + y^2 = (25)^2$$

$$x^2 + (35 - x)^2 = 625$$

$$x^2 - 35x + 300 = 0$$

$$(x - 20)(x - 15) = 0$$

$$\Rightarrow x = 20, 15$$

$$x = 20 \Rightarrow y = 15$$

$$x = 15 \Rightarrow y = 20$$

Hence sides are 15 cm and 20 cm.

(2024)

1. The greater of two supplementary angles exceeds the smaller by  $18^\circ$ . Find measures of these two angles. (2024)

**Answer.** Let the measure of two angles be  $x^\circ$  and  $y^\circ$  ( $x > y$ )

Given  $x + y = 180$  and  $x - y = 18$

solving equations to get  $y = 81$  and  $x = 99$

2. If a line is drawn parallel to one side of a triangle to intersect the other two sides in distinct points, then prove that other two sides are divided in the same ratio. (2024)

**Answer.** (A)

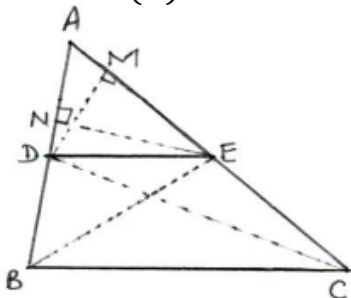

Given: In  $\triangle ABC$ ,  $DE \parallel BC$

To Prove:  $\frac{AD}{DB} = \frac{AE}{EC}$

Construction: Join BE, DC

Draw  $DM \perp AC$  and  $EN \perp AB$

Proof: 
$$\frac{\text{ar}(\triangle ADE)}{\text{ar}(\triangle BDE)} = \frac{\frac{1}{2} \times AD \times EN}{\frac{1}{2} \times DB \times EN}$$

$$\frac{\text{ar}(\triangle ADE)}{\text{ar}(\triangle BDE)} = \frac{AD}{DB} \quad \dots\dots\dots(i)$$

$$\text{and } \frac{\text{ar}(\triangle ADE)}{\text{ar}(\triangle CDE)} = \frac{\frac{1}{2} \times AE \times DM}{\frac{1}{2} \times EC \times DM}$$

$$\frac{\text{ar}(\triangle ADE)}{\text{ar}(\triangle CDE)} = \frac{AE}{EC} \quad \dots\dots\dots(ii)$$

$\triangle BDE$  and  $\triangle CDE$  are on the same base DE and between the same parallels DE and BC.

$$\therefore \text{ar}(\triangle BDE) = \text{ar}(\triangle CDE) \quad \dots\dots\dots(iii)$$

From (i), (ii) and (iii)

$$\frac{AD}{DB} = \frac{AE}{EC}$$

3. Sides AB and BC and median AD of a  $\triangle ABC$  are respectively proportional to sides PQ and PR and median PM of  $\triangle PQR$ . Show that (2024)  
 $\triangle ABC \sim \triangle PQR$ .

Answer. (B) Produce AD to E and PM to N such that  $AD = DE$ ,  $PM = MN$ .

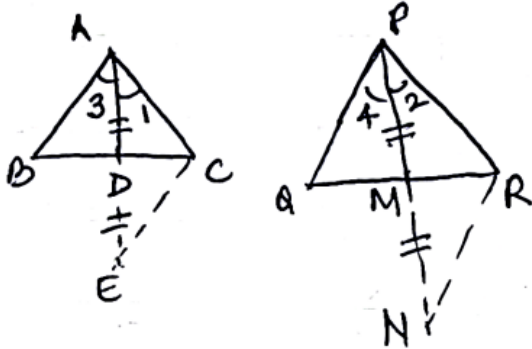

$\triangle ADB \cong \triangle EDC \Rightarrow AB = CE$ , similarly  $PQ = RN$ .

Given  $\frac{AB}{PQ} = \frac{AC}{PR} = \frac{AD}{PM}$

$$\Rightarrow \frac{CE}{RN} = \frac{AC}{PR} = \frac{\frac{AE}{2}}{\frac{PN}{2}} \Rightarrow \triangle AEC \sim \triangle PNR$$

$\Rightarrow \angle 1 = \angle 2$ , similarly  $\angle 3 = \angle 4$

therefore  $\angle 1 + \angle 3 = \angle 2 + \angle 4$  or  $\angle BAC = \angle QPR$

Also  $\frac{AB}{PQ} = \frac{AC}{PR}$  (given)

Therefore  $\triangle ABC \sim \triangle PQR$

4. In the given figure, ABCD is a quadrilateral.

Diagonal BD bisects  $\angle B$  and  $\angle D$  both. (2024)

Prove that:

(i)  $\triangle ABD \sim \triangle CBD$

(ii)  $AB = BC$

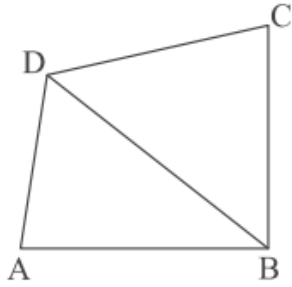

**Answer.** (i) In  $\triangle ABD$  &  $\triangle CBD$

$$\angle 3 = \angle 4$$

$$\angle 1 = \angle 2$$

$$\therefore \triangle ABD \sim \triangle CBD$$

(ii)  $\triangle ABD \cong \triangle CBD$

$$\therefore AB = BC$$

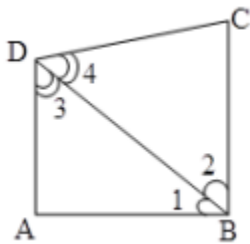

**5. If a line is drawn parallel to one side of a triangle to intersect the other two sides in distinct points, then prove that the other two sides are divided in the same ratio. (2024)**

**Answer.** Correct figure, given, to prove and construction Correct proof

**6. In the given figure PA, QB and RC are each perpendicular to AC. If (2024)**

**AP = x, BQ = y and CR = z, then**

prove that  $\frac{1}{x} + \frac{1}{z} = \frac{1}{y}$

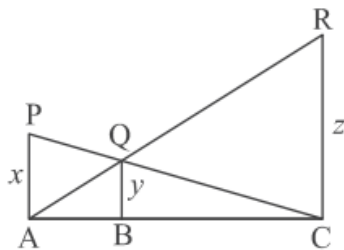

**Answer.**

$$\Delta PAC \sim \Delta QBC$$

$$\therefore \frac{x}{y} = \frac{AC}{BC} \text{ or } \frac{y}{x} = \frac{BC}{AC} \text{ ---- (i)}$$

$$\Delta RCA \sim \Delta QBA$$

$$\therefore \frac{z}{y} = \frac{AC}{AB} \text{ or } \frac{y}{z} = \frac{AB}{AC} \text{ ---- (ii)}$$

Adding (i) and (ii)

$$\frac{y}{x} + \frac{y}{z} = \frac{BC+AB}{AC}$$

$$\Rightarrow \frac{1}{x} + \frac{1}{z} = \frac{1}{y}$$

## 6.2 Similar Figures

VSA (1 mark)

1. All concentric circles are \_\_\_\_\_ to each other. (2020)
2. Two polygons having same number of sides and corresponding sides proportional are similar or not? (Board Term 1, 2016)

## 6.3 Similarity of Triangles

MCQ

3. In  $\triangle ABC$ ,  $PQ \parallel BC$ . If  $PB = 6$  cm,  $AP = 4$  cm,  $AQ = 8$  cm, find the length of  $AC$ .

- (a) 12 cm
- (b) 20 cm
- (c) 6 cm
- (d) 14 cm

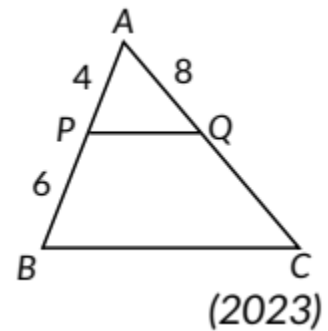

4. In the given figure,  $PQ \parallel AC$ . If  $BP = 4$  cm,  $AP = 2.4$  cm and  $BQ = 5$  cm, then length of  $BC$  is

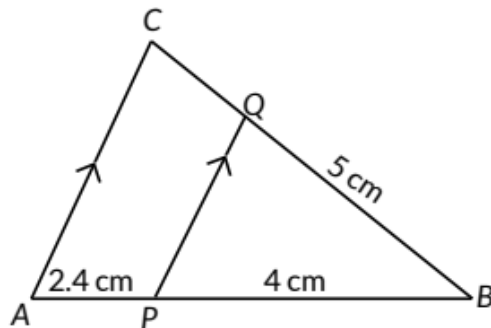

- (a) 8 cm
  - (b) 3 cm
  - (c) 0.3 cm
  - (d)  $\frac{25}{3}$  cm
- (2023)

5. In the figure given below, what value of  $x$  will make  $PQ \parallel AB$ ?

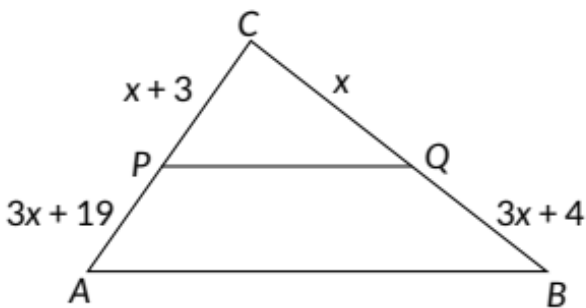

- (a) 2
- (c) 4
- (b) 3
- (d) 5 (Term 1, 2021-22)

6.

In figure,  $DE \parallel BC$ . If  $\frac{AD}{DB} = \frac{3}{2}$  and  $AE = 2.7$  cm, then  $EC$  is equal to

- (a) 2.0 cm
- (b) 1.8 cm
- (c) 4.0 cm
- (d) 2.7 cm

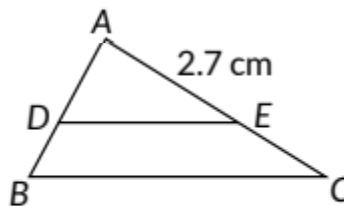

(2020)

VSA (1 mark)

7. In figure,  $GC \parallel BD$  and  $GE \parallel BF$ . If  $AC = 3$  cm and

$CD = 7$  cm, then find the value of  $\frac{AE}{AF}$ . (2019C)

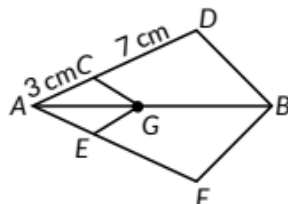

8. In  $\triangle ABC$ ,  $X$  is middle point of  $AC$ . If  $XY \parallel AB$ , then prove that  $Y$  is middle point of  $BC$ . (Board Term I, 2017)

9. In  $\triangle ABC$ ,  $D$  and  $E$  are point on side  $AB$  and  $AC$  respectively, such that  $DE \parallel BC$ . If  $AE = 2$  cm,  $AD = 3$  cm and  $BD = 4.5$  cm, then find  $CE$ . (Board Term I, 2017)

10. In  $\triangle ABC$ ,  $DE \parallel BC$ , then find the value of  $x$ .

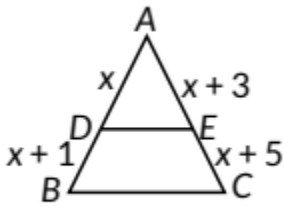

(Board Term I, 2017)

11. In given figure,  $DE \parallel BC$

If  $\frac{AD}{DB} = \frac{3}{4}$  and  $AC = 14$  cm, find  $EC$ .

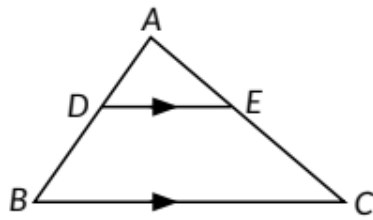

(Board Term I, 2017)

**SAI (2 marks)**

12. In the given figure,  $DE \parallel AC$  and  $DF \parallel AE$ .

Prove that  $\frac{BF}{FE} = \frac{BE}{EC}$ .

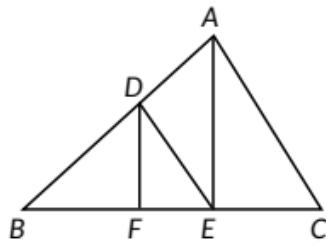

(NCERT, 2020)

In figure,  $DE \parallel AC$  and  $DC \parallel AP$ . Prove that  $\frac{BE}{EC} = \frac{BC}{CP}$ .

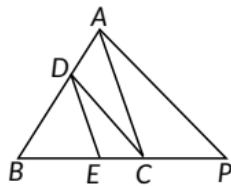

(2020) (Ap)

13. In figure, if  $PQ \parallel BC$  and  $PR \parallel CD$ , prove that

$$\frac{QB}{AQ} = \frac{DR}{AR}$$

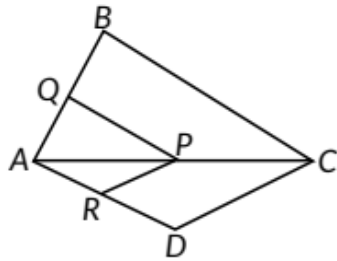

(2020)

SA II (3 marks)

14.

In figure  $\angle D = \angle E$  and  $\frac{AD}{DB} = \frac{AE}{EC}$ , prove that  $\triangle ABC$  is an isosceles triangle.



(2020) 

15. In the figure, P is any point on side BC of  $\triangle ABC$ .  $PQ \parallel BA$  and  $PR \parallel CA$  are drawn. RQ is extended to meet BC produced at S. Prove that  $SP^2 = SB \times SC$ .

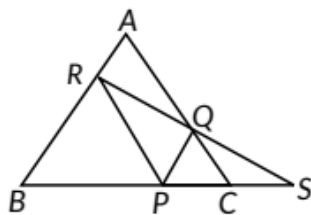

(Board Term I, 2017)

LA (4/5/6 marks)

16. If a line is drawn parallel to one side of a triangle to intersect the other two sides at distinct points, prove that the other two sides are divided in the same ratio. (2020, 2015)

OR

State and prove Basic Proportionality Theorem (Thales Theorem). (Board Term 1, 2015)

17. ABCD is a trapezium with  $AB \parallel CD$ . E and F are points on non parallel sides AD and BC respectively, such

that  $EF \parallel AB$ . Show that  $\frac{AE}{ED} = \frac{BF}{FC}$  (2019C)

## 6.4 Criteria for Similarity of Triangles

### MCQ

18. In the given figure,  $\triangle ABC \sim \triangle PQR$ . If  $AC = 6$  cm,  $BC = 5$  cm,  $QR = 3$  cm and  $PR = x$ , then the value of  $x$  is

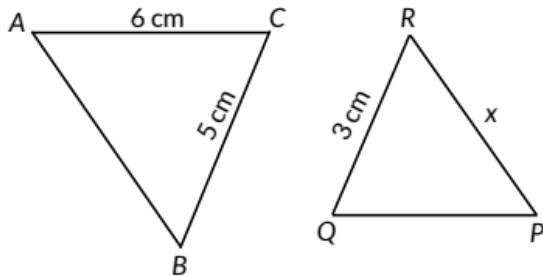

- (a) 3.6 cm
- (c) 10 cm
- (b) 2.5 cm
- (d) 3.2 cm (2023)

19. If  $\triangle ABC$  and  $\triangle PQR$  are similar triangles such that  $\angle A = 31^\circ$  and  $\angle R = 69^\circ$ , then  $\angle Q$  is

- (a)  $70^\circ$
- (b)  $100^\circ$
- (c)  $90^\circ$
- (d)  $80^\circ$  (Term I, 2021-22)

20. A vertical pole of length 19 m casts a shadow 57 m long on the ground and at the same time a tower casts a shadow 51 m long. The height of the tower is

- (a) 171m
- (b) 13 m
- (c) 17 m
- (d) 117 m (Term I, 2021-22)

21. In the given figure,  $\angle ABC$  and  $\angle ACB$  are complementary to each other and  $AD \perp BC$ . Then,

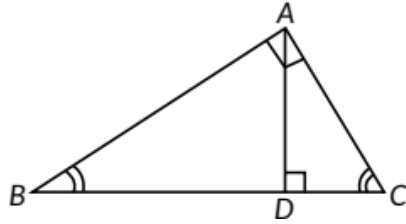

- (a)  $BD \cdot CD = BC^2$   
 (c)  $BD \cdot CD = AD^2$   
 (b)  $AB \cdot BC = BC^2$   
 (d)  $AB \cdot AC = AD^2$  (Term I, 2021-22)

22. In the given figure,  $x$  expressed in terms of  $a, b, c$ , is

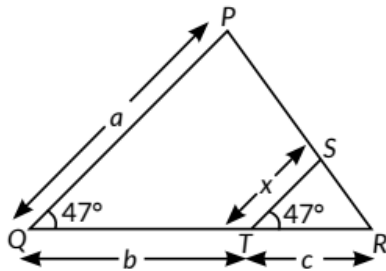

- (a)  $x = \frac{ab}{a+b}$                       (b)  $x = \frac{ac}{b+c}$   
 (c)  $x = \frac{bc}{b+c}$                       (d)  $x = \frac{ac}{a+c}$

(Term I, 2021-22)

**SAI (2 marks)**

23. In the given figure,  $XZ$  is parallel to  $BC$ .  $AZ = 3$  cm,  $ZC = 2$  cm,  $BM = 3$  cm and  $MC = 5$  cm. Find the length of  $XY$ .

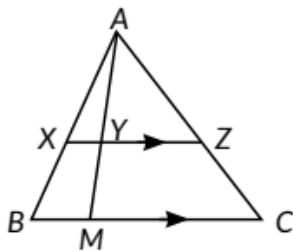

(2023)

25. State which of the two triangles given in the figure are similar. Also state the similarity criterion used.

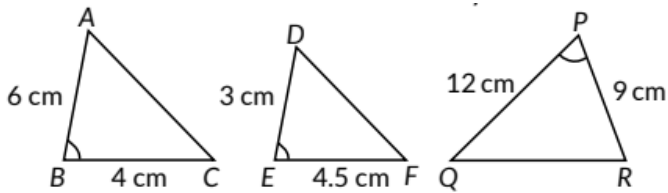

(Board Term I, 2016)

26. Sides AB, BC and median AD of a  $\Delta ABC$  are respectively proportional to sides PQ, QR and median PM of  $\Delta PQR$ . Show that  $\Delta ABC \sim \Delta PQR$ . (Board Term 1, 2015)

SA II (3 marks)

27. PA, QB and RC are each perpendicular to AC. If  $AP = x$ ,  $QB = z$ ,  $RC = y$ ,  $AB = a$  and  $BC = b$ , then prove

that  $\frac{1}{x} + \frac{1}{y} = \frac{1}{z}$ .

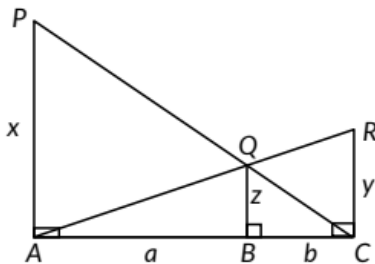

(2023)

28. In the given figure, CD and RS are respectively the medians of  $\Delta ABC$  and  $\Delta PQR$ . If  $\Delta ABC \sim \Delta PQR$  then prove that:

(i)  $\Delta ADC \sim \Delta PSR$

(ii)  $AD \times PR = AC \times PS$

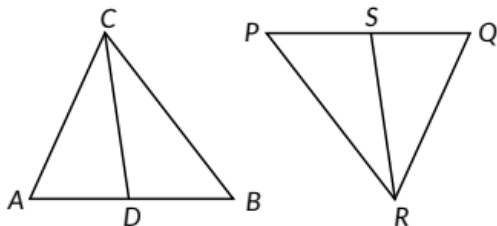

(2023)

29. In the figure, if  $\Delta BEA = \Delta CDA$ , then prove that

$\triangle DEA \sim \triangle BCA$ .

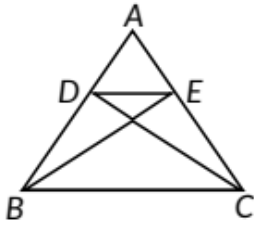

(Board Term I, 2017)

30. In  $\triangle ABC$ ,  $\angle ADE = \angle B$  then prove that  $\triangle ADE \sim \triangle ABC$  also if  $AD = 7.6$  cm,  $BD = 4.2$  cm and  $BC = 8.4$  cm, then find  $DE$ .

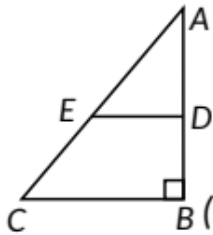

(Board Term I, 2017)

31. A girl of height 100 cm is walking away from the base of a lamp post at a speed of 1.9 m/s. If the lamp is 5 m above the ground, find the length of her shadow after 4 seconds. (Board Term 1, 2016)

32.  $\triangle ABC$  and  $\triangle AMP$  are two right angled triangles right angled at  $B$  and  $M$  respectively. Prove that  $CA \times MP = PA \times BC$ .

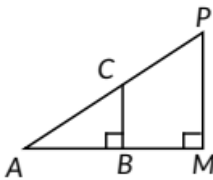

(Board Term I, 2016)

**LA (4/5/6 marks)**

33. (A) In a  $\triangle PQR$ ,  $N$  is a point on  $PR$ , such that  $QN \perp PR$ . If  $PN \times NR = QN^2$ , prove that  $\angle PQR = 90^\circ$ . (2023)

34. In the given figure,  $\triangle ABC$  and  $\triangle DBC$  are on the same base  $BC$ . If  $AD$  intersects  $BC$  at  $O$ , prove that

$$\frac{\text{ar}(\triangle ABC)}{\text{ar}(\triangle DBC)} = \frac{AO}{DO}$$

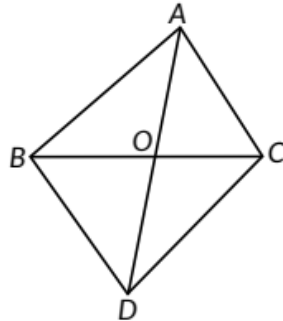

(2023)

35. In the given figure,  $E$  is a point on  $CB$  produced of an isosceles  $\triangle ABC$ , with side  $AB = AC$ . If  $AD \perp BC$  and  $EF \perp AC$ , prove that  $\triangle ABD \sim \triangle AECF$ .

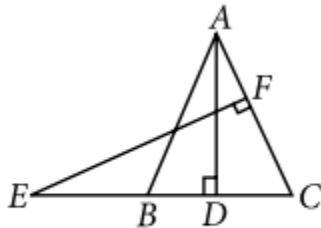

(NCERT, AI 2019) U

36. In the given figure,  $ABC$  is a triangle and  $GHED$  is a rectangle.  $BC = 12$  cm,  $HE = 6$  cm,  $FC = BF$  and altitude  $AF = 24$  cm. Find the area of the rectangle.

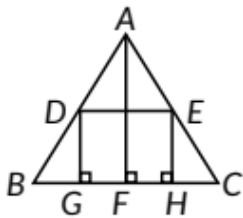

(Board Term I, 2017)

37. Two poles of height ' $p$ ' and ' $q$ ' metres are standing vertically on a level ground, ' $a$ ' metres apart. Prove that the height of the point of intersection of the lines joining the top of each pole to the foot of the opposite

pole is given by  $\frac{pq}{p+q}$ . (Board Term I, 2017)

38. In  $\triangle ABC$ , from A and B altitudes AD and BE are drawn. Prove that  $\triangle ADC \sim \triangle BEC$ . Is  $\triangle ADB \sim \triangle AEB$  and  $\triangle ADB \sim \triangle ADC$ ? (Board Term 1, 2016)

## Pythagoras Theorem

### MCQ

39. Assertion (A): The perimeter of  $\triangle ABC$  is a rational number.

Reason (R): The sum of the squares of two rational numbers is always rational.

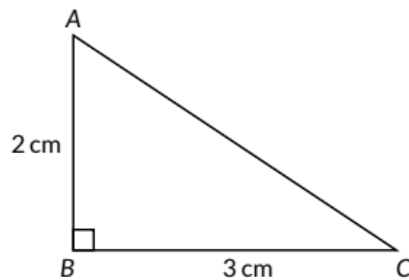

- (a) Both Assertion (A) and Reason (R) are true and Reason (R) is the correct explanation of Assertion (A).
- (b) Both Assertion (A) and Reason (R) are true, but Reason (R) is not the correct explanation of the Assertion (A).
- (c) Assertion (A) is true, but Reason (R) is false.
- (d) Assertion (A) is false but Reason (R) is true. (2023)

### VSA (1 marks)

40. Aman goes 5 metres due west and then 12 metres due North. How far is he from the starting point? (2021 C)

### SA II (3 marks)

41. In  $\triangle ABC$ ,  $\angle B = 90^\circ$  and D is the mid point of BC. Prove that  $AC^2 = AD^2 + 3CD^2$

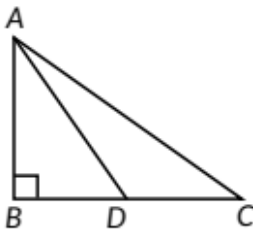

(2019)

42. Prove that the sum of squares of the sides of a rhombus is equal to the sum of squares of its diagonals. (2019)

**LA (4/5/6 marks)**

43. In given figure BN and CM are medians of a right angled at A. Prove that  $4(BN^2 + CM^2) = 5BC^2$

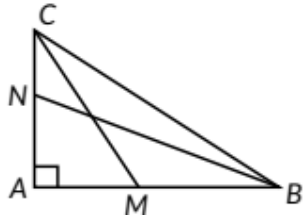

(2020C)

44. The perpendicular from A on the side BC of a  $\Delta ABC$  intersects BC at D, such that  $DB = 3CD$ . Prove that  $2AB^2 = 2AC^2 + BC^2$ .

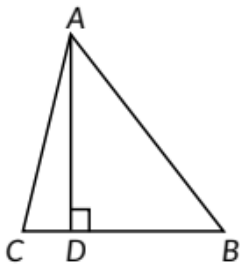

(2019C)

## CBSE Sample Questions

### 6.3 Similarity of Triangles

**VSA (1 mark)**

1. In the  $\Delta ABC$ , D and E are points on side AB and AC respectively such that  $DE \parallel BC$ . If  $AE = 2$  cm,  $AD = 3$  cm and  $BD = 4.5$  cm, then find CE. (2020-21)

**LA (4/5/6 marks)**

2. Prove that if a line is drawn parallel to one side of a triangle intersecting the other two sides in distinct points, then the other two sides are divided in the same ratio.

Using the above theorem prove that a line through the point of intersection of the diagonals and parallel to the base of the trapezium divides the non parallel sides in the same ratio. (2022-23)

## 6.4 Criteria for Similarity of Triangles

### MCQ

3.  $\Delta ABC \sim \Delta PQR$ . If AM and PN are altitudes of  $\Delta ABC$  and  $\Delta PQR$  respectively and  $AB^2 : PQ^2 = 4 : 9$ , then AM: PN=
- (a) 3:2
  - (b) 16:81
  - (c) 4:9
  - (d) 2:3 (2022-23)

OR

$\Delta ABC \sim \Delta PQR$ . If AM and PN are altitudes of  $\Delta ABC$  and  $\Delta PQR$  respectively and  $AB^2 : PQ^2 = 4 : 9$ , then

AM: PN=

- (a) 16:81
- (b) 4:9
- (c) 3:2
- (d) 2:3 (Term I, 2021-22)

In the figure, if  $DE \parallel BC$ ,  $AD = 3$  cm,  $BD = 4$  cm and  $BC = 14$  cm, then DE equals

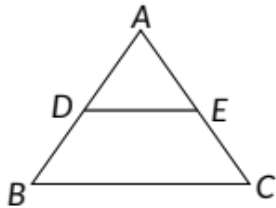

- (a) 7 cm
- (b) 6 cm
- (c) 4 cm
- (d) 3 cm (Term 1, 2021-22)

5.  $\Delta ABC$  is such that  $AB = 3$  cm,  $BC = 2$  cm,  $CA = 2.5$  cm. If  $\Delta ABC \sim \Delta DEF$  and  $EF = 4$  cm, then perimeter of  $\Delta DEF$  is

- (a) 7.5 cm
- (b) 15 cm
- (c) 22.5 cm
- (d) 30 cm (Term I, 2021-22)

6. In the given figure,  $\angle ZACB = \angle CDA$ ,  $AC = 8$  cm,  $AD = 3$  cm, then  $BD$  is

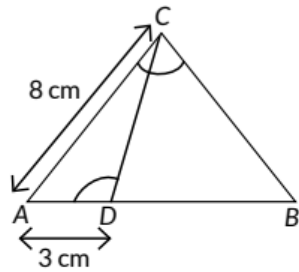

- (a)  $\frac{22}{3}$  cm (b)  $\frac{26}{3}$  cm (c)  $\frac{55}{3}$  cm (d)  $\frac{64}{3}$  cm

(Term I, 2021-22) **An**

7. Sides  $AB$  and  $BE$  of a right triangle, right angled at  $B$  are of lengths  $16$  cm and  $8$  cm respectively. The length of the side of largest square  $FDGB$  that can be inscribed in the triangle  $ABE$  is

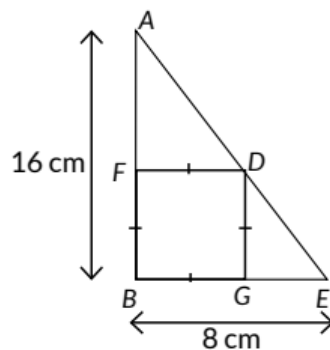

- (a)  $\frac{32}{3}$  cm (b)  $\frac{16}{3}$  cm (c)  $\frac{8}{3}$  cm (d)  $\frac{4}{3}$  cm

(Term I, 2021-22) (

Case study-based questions are compulsory. Attempt any 4 sub parts. Each question carries 1 mark.

## 8. SCALE FACTOR AND SIMILARITY

### Scale Factor

A scale drawing of an object is the same shape as the object but a different size. The scale of a drawing is a comparison of the length used on a drawing to the length it represents. The scale is written as a ratio.

### Similar Figures

The ratio of two corresponding sides in similar figures is called the scale factor.

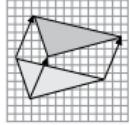

Translation or Slide

Hence, two shapes are Similar when one can become the other after a resize, flip, slides or turn.

(i) A model of a boat is made on the scale of 1: 4. The model is 120 cm long. The full size of the boat has a width of 60 cm. What is the width of the scale model?



- (a) 20 cm (b) 25 cm (c) 15 cm (d) 240 cm
- (ii) What will effect the similarity of any two polygons?
- (a) They are flipped horizontally  
(b) They are dilated by a scale factor  
(c) They are translated down  
(d) They are not the mirror image of one another
- (iii) If two similar triangles have a scale factor of a: b. Which statement regarding the two triangles is true?
- (a) The ratio of their perimeters is 3a: b  
(b) Their altitudes have a ratio a: b  
(c) Their medians have a ratio  $\frac{a}{2} : b$   
(d) Their angle bisectors have a ratio  $a^2 : b^2$
- (iv) The shadow of a stick 5 m long is 2 m. At the same time the shadow of a

tree 12.5m high is

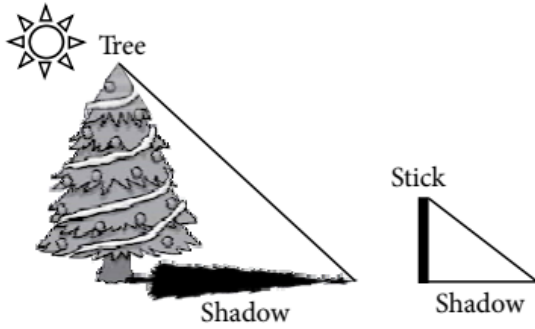

- (a) 3m (b) 3.5 m (c) 4.5m (d) 5m

(v) Below you see a student's mathematical model of a farmhouse roof with measurements. The attic floor, ABCD in the model, is a square. The beams that support the roof are the edges of a rectangular prism, EFGHKL MN. E is the middle of AT, F is the middle of BT, G is the middle of CT, and H is the middle of DT. All the edges of the pyramid in the model have length of 12 m.

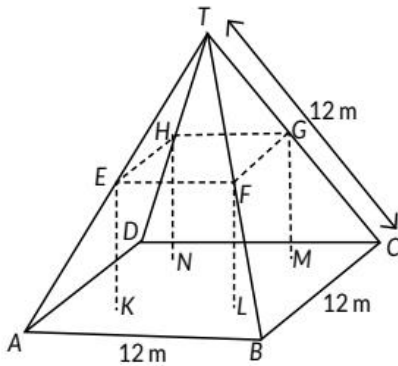

What is the length of EF, where EF is one of the horizontal edges of the block?

- (a) 24 m  
 (b) 3m  
 (c) 6m  
 (d) 10 m (2020-21)

SAI (2 marks)

9.

In the given figure below,  $\frac{AD}{AE} = \frac{AC}{BD}$  and  $\angle 1 = \angle 2$ .

Show that  $\triangle BAE \sim \triangle CAD$ .

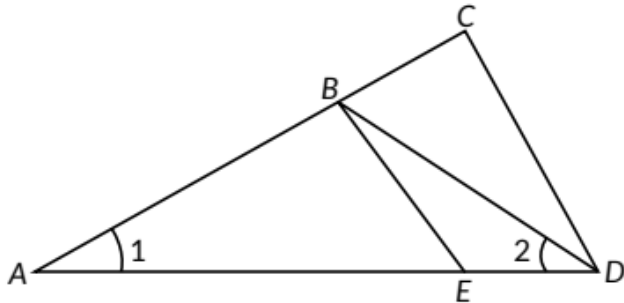

(2022-23)

SA II (3 marks)

10. The perimeters of two similar triangles are 25 cm and 15 cm respectively. If one side of the first triangle is 9 cm, find the length of the corresponding side of the second triangle. (2020-21)

## SOLUTIONS

### Previous Years' CBSE Board Questions

1. All concentric circles are similar to each other.
2. Two polygons having same number of sides and corresponding sides proportional are not similar.
3. (b): Since,  $PQ \parallel BC$

$$\therefore \frac{AP}{PB} = \frac{AQ}{QC} \quad \text{[By Thales theorem]}$$

$$\Rightarrow \frac{4}{6} = \frac{8}{QC} \Rightarrow QC = \frac{8 \times 6}{4} = 12 \text{ cm}$$

4. (a): Since,  $PQ \parallel AC$ .

$$\therefore \frac{BQ}{QC} = \frac{BP}{AP}$$

$$\Rightarrow \frac{5}{QC} = \frac{4}{2.4} \quad [\because BP = 4 \text{ cm}, AP = 2.4 \text{ cm and } BQ = 5 \text{ cm}]$$

$$\Rightarrow QC = \frac{5 \times 2.4}{4} = 3 \text{ cm}$$

$$\therefore BC = BQ + QC = 5 + 3 = 8 \text{ cm}$$

5. (a): Suppose  $PQ \parallel AB$

:- By Basic Proportionality theorem, we have

$$\frac{CP}{PA} = \frac{CQ}{QB} \Rightarrow \frac{x+3}{3x+19} = \frac{x}{3x+4}$$

$$\Rightarrow 3x^2 + 19x = 3x^2 + 9x + 4x + 12$$

$$\Rightarrow 6x = 12 \Rightarrow x = 2$$

So, for  $x = 2$ ,  $PQ \parallel AB$ .

6. (b): In  $\triangle ABC$ ,  $DE \parallel BC$

$$\therefore \frac{AD}{DB} = \frac{AE}{EC}$$

[By B.P.T.]

$$\Rightarrow \frac{3}{2} = \frac{2.7}{EC}$$

[Given]

$$\Rightarrow 3EC = 2 \times 2.7$$

$$\Rightarrow EC = \frac{5.4}{3} = 1.8 \text{ cm}$$

7. Here in the given figure,

$GC \parallel BD$  and  $GE \parallel BF$

$AC = 3 \text{ cm}$  and  $CD = 7 \text{ cm}$

By Basic Proportionality theorem,

$$\text{we get } \frac{AC}{CD} = \frac{AE}{EF}$$

$$\therefore \frac{AE}{EF} = \frac{3}{7} \Rightarrow \frac{AF}{AE} = \frac{7}{3} \Rightarrow \frac{AE+EF}{AE} = \frac{3+7}{3}$$

$$\Rightarrow \frac{AF}{AE} = \frac{10}{3}$$

$$\therefore \frac{AE}{AF} = \frac{3}{10}$$

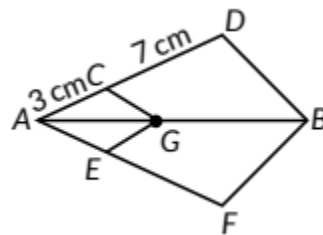

8. Given, X is middle point of AC and  $XY \parallel AB$ . We have to prove Y is middle point of BC. In  $\triangle ABC$ ,  $XY \parallel AB$

$$\therefore \frac{CX}{XA} = \frac{CY}{YB} \quad [\text{By B.P.T.}] \dots(i)$$

But X is the middle point of AC  
 $\Rightarrow CX = XA \dots(ii)$

From (i) and (ii), we get

$$1 = \frac{CY}{YB}$$

$$\Rightarrow CY = YB$$

$\therefore$  Y is middle point of BC

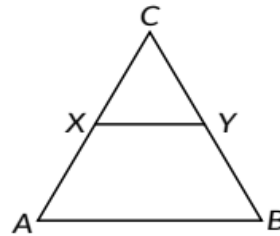

9.

In  $\triangle ABC$ ,  $DE \parallel BC$

$$\therefore \frac{AD}{DB} = \frac{AE}{EC} \quad [\text{By B.P.T.}]$$

$$\Rightarrow \frac{3}{4.5} = \frac{2}{EC}$$

$$\Rightarrow 3EC = 9 \Rightarrow EC = 3 \text{ cm}$$

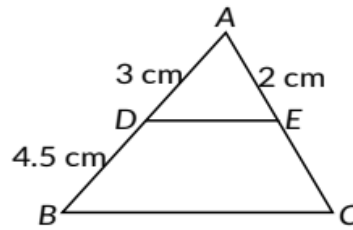

10.

In  $\triangle ABC$ ,  $DE \parallel BC$

$$\therefore \frac{AD}{DB} = \frac{AE}{EC} \quad [\text{By B.P.T.}]$$

$$\Rightarrow \frac{x}{x+1} = \frac{x+3}{x+5} \Rightarrow x(x+5) = (x+3)(x+1)$$

$$\Rightarrow x^2 + 5x = x^2 + 3x + x + 3 \Rightarrow x = 3$$

11.

In  $\triangle ABC$ ,  $DE \parallel BC$

$$\therefore \frac{AD}{DB} = \frac{AE}{EC} \quad [\text{By B.P.T.}]$$

$$\Rightarrow \frac{3}{4} = \frac{AC - EC}{EC} \quad [\text{Given}]$$

$$\Rightarrow \frac{3}{4} = \frac{14 - EC}{EC}$$

$$\Rightarrow 3EC = 56 - 4EC \Rightarrow 7EC = 56 \Rightarrow EC = 8 \text{ cm}$$

12.

In  $\triangle ABC$ , we have  $DE \parallel AC$

$$\Rightarrow \frac{BE}{EC} = \frac{BD}{DA} \quad [\text{By B.P.T}] \dots(i)$$

In  $\triangle ABE$ ,  $DF \parallel AE$

$$\Rightarrow \frac{BF}{FE} = \frac{BD}{DA} \quad [\text{By B.P.T}] \dots(ii)$$

From (i) and (ii), we have  $\frac{BF}{FE} = \frac{BE}{EC}$   
Hence proved.

13.

In  $\triangle ABC$ ,  $PQ \parallel BC$

$$\Rightarrow \frac{AQ}{QB} = \frac{AP}{PC} \quad [\text{By B.P.T.}] \dots(i)$$

In  $\triangle ACD$ ,  $PR \parallel CD$

$$\Rightarrow \frac{AR}{DR} = \frac{AP}{PC} \quad [\text{By B.P.T.}] \dots(ii)$$

From (i) and (ii),  $\frac{AQ}{QB} = \frac{AR}{DR} \Rightarrow \frac{QB}{AQ} = \frac{DR}{AR}$   
Hence proved.

14.

$$\text{Given, } \frac{AD}{DB} = \frac{AE}{EC} \text{ and } \angle D = \angle E \quad \dots(i)$$

We have to prove that  $\triangle ABC$  is an isosceles triangle.

$$\text{Now, in } \triangle ABC, \frac{AD}{DB} = \frac{AE}{EC} \quad [\text{Given}]$$

$\therefore DE \parallel BC$

[By Converse of Basic Proportionality Theorem]

Also,  $\angle D = \angle B$  and  $\angle E = \angle C$  [Corresponding angles]  $\dots(ii)$

From (i) and (ii), we get  $\angle B = \angle C \Rightarrow AB = AC$

[Sides opposite to equal angles are equal]

$\therefore \triangle ABC$  is an isosceles triangle.

15.

In  $\triangle SRB$ ,  $PQ \parallel RB$   
 $\Rightarrow \frac{SP}{SB} = \frac{SQ}{SR}$  [By B.P.T.] ... (i)

Also, in  $\triangle SPR$ ,  $PR \parallel QC$   
 $\Rightarrow \frac{SC}{SP} = \frac{SQ}{SR}$  [By B.P.T.] ... (ii)

From (i) and (ii), we get,

$$\frac{SP}{SB} = \frac{SC}{SP} \Rightarrow SP^2 = SB \times SC$$

Hence proved.

16. Consider  $\triangle ABC$  in which  $DE \parallel BC$ ,  $DE$  intersects  $AB$  at  $D$  and  $AC$  at  $E$ .

To prove:  $\frac{AD}{DB} = \frac{AE}{EC}$

Construction : Join  $BE$ ,  $CD$  and draw  $EF \perp AB$ ,  $DG \perp AC$ .

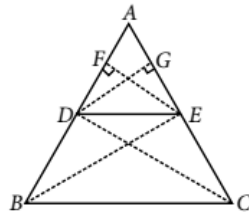

Proof: Area of  $\triangle EAD$

$$= \frac{1}{2} \times (\text{base} \times \text{height}) = \frac{1}{2} \times AD \times EF$$

$$\text{So, area}(\triangle EAD) = \frac{1}{2} AD \times EF$$

$$\text{Again, area of } \triangle EDB = \frac{1}{2} \times (\text{base} \times \text{height}) = \frac{1}{2} \times DB \times EF$$

$$\text{So, area}(\triangle EDB) = \frac{1}{2} DB \times EF$$

$$\therefore \frac{\text{area}(\triangle EAD)}{\text{area}(\triangle EDB)} = \frac{AD}{DB} \quad \dots (i)$$

$$\text{Similarly, } \frac{\text{area}(\triangle EAD)}{\text{area}(\triangle ECD)} = \frac{AE}{EC} \quad \dots (ii)$$

Since, triangles  $EDB$  and  $ECD$  are on the same base  $DE$  and between the same parallel lines  $DE$  and  $BC$ .  
 So,  $\text{area}(\triangle EDB) = \text{area}(\triangle ECD)$  ... (iii)

$$\text{From (i), (ii) and (iii), we have } \frac{AD}{DB} = \frac{AE}{EC}$$

17.

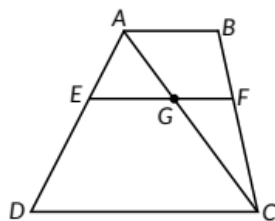

First join AC to intersect EF at G.

Given  $AB \parallel DC$  and  $EF \parallel AB$

$\Rightarrow EF \parallel DC \dots(i)$

[ $\because$  Lines parallel to same line are parallel to each other.]

Now in  $\triangle ADC$ , we have

$EG \parallel DC$  ( $\because EF \parallel DC$ )

$$\Rightarrow \frac{AE}{ED} = \frac{AG}{GC} \quad (\text{By B.P.T.}) \quad \dots(ii)$$

Similarly in  $\triangle CAB$ , we have

$$\frac{CG}{AG} = \frac{CF}{BF} \quad (\text{By B.P.T.})$$

$$\Rightarrow \frac{AG}{GC} = \frac{BF}{FC} \quad \dots(iii)$$

From (ii) and (iii), we get

$$\frac{AE}{ED} = \frac{BF}{FC}$$

Hence proved.

18.

(b): Given,  $\triangle ABC \sim \triangle QPR$

$$\therefore \frac{AB}{QP} = \frac{BC}{PR} = \frac{AC}{QR} \quad \therefore \frac{5}{x} = \frac{6}{3} \Rightarrow x = \frac{5 \times 3}{6} = 2.5$$

$$\Rightarrow x = 2.5 \text{ cm}$$

19.

(d):

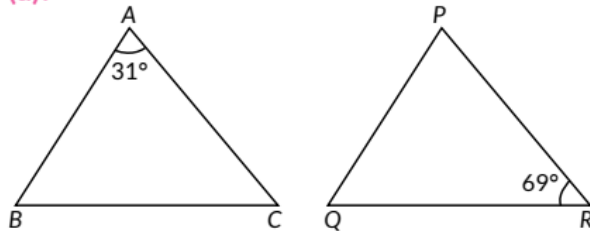

Given,  $\angle A = 31^\circ$ ,  $\angle R = 69^\circ$  and  $\triangle ABC \sim \triangle PQR$

$\therefore \angle ZP = \angle A = 31^\circ$

$\therefore \angle ZQ = 180^\circ - (31^\circ + 69^\circ)$  [By angle sum property]

$$= \angle ZQ = 80^\circ$$

20. (c): Let AB be the pole and PQ be the tower.  
Let height of tower be h m.

Now,  $\triangle ABC \sim \triangle PQR$

$$\therefore \frac{AB}{PQ} = \frac{BC}{QR}$$

$$\Rightarrow \frac{19}{h} = \frac{57}{51}$$

$$\Rightarrow h = \frac{19 \times 51}{57}$$

$$\Rightarrow h = 17 \text{ m}$$

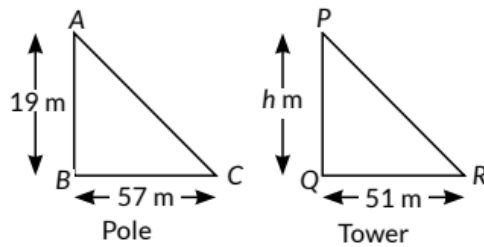

21. (c): We have,

$$\angle ABC + \angle ACB = 90^\circ \text{ [Given] . (i)}$$

In  $\triangle BDA$ ,  $\angle ABD + \angle BAD = 90^\circ \dots$  (ii) [By angle sum property]

From (i) and (ii), we get,  $\angle ACB = \angle BAD$

In  $\triangle ADC$  and  $\triangle BDA$

$$\angle ADC = \angle BDA = 90^\circ$$

$$\angle ACD = \angle BAD \text{ [Proved above]}$$

$\therefore \triangle ADC \sim \triangle BDA$  [By AA similarity]

22. (b): In  $\triangle RST$  and  $\triangle RPQ$ ,

$$\angle R = \angle R \text{ [Common]}$$

$$\angle RTS = \angle RQP = 47^\circ \text{ [Given]}$$

$\triangle RST \sim \triangle RPQ$  [By AA similarity]

$$\therefore \frac{ST}{PQ} = \frac{RT}{RQ} \Rightarrow \frac{x}{a} = \frac{c}{c+b} \Rightarrow x = \frac{ac}{b+c}$$

23. (a) Given,  $AZ = 3 \text{ cm}$ ,  $ZC = 2 \text{ cm}$ ,  $BM = 3 \text{ cm}$  and  $MC = 5 \text{ cm}$

In  $\triangle ABC$ ,  $XZ \parallel BC$

$$\therefore \frac{AX}{AB} = \frac{AY}{AM} = \frac{AZ}{AC} \text{ (Thales theorem) } \dots(i)$$

Now,  $AC = AZ + ZC = 3 + 2 = 5 \text{ cm}$

$BC = BM + MC = 3 + 5 = 8 \text{ cm}$  and

In  $\triangle AXY$  and  $\triangle ABM$

$\angle AXY = \angle ABM$  (Corresponding angles are equal, as  $XZ \parallel BC$ )

$\angle XAY = \angle BAM$  (Common)

$\therefore \triangle AXY \sim \triangle ABM$  (By AA similarity criterion)

$$\therefore \frac{AX}{AB} = \frac{XY}{BM} = \frac{AY}{AM} \quad \dots(ii)$$

(Corresponding sides of similar triangles.)

From (i) and (ii), we get  $\frac{XY}{BM} = \frac{AZ}{AC}$

$$\Rightarrow \frac{XY}{3} = \frac{3}{5}$$

$$\Rightarrow XY = \frac{3 \times 3}{5} = \frac{9}{5} = 1.8 \text{ cm}$$

24. Given,  $PQ \parallel BC$

$PQ = 3 \text{ cm}$ ,  $BC = 9 \text{ cm}$  and  $AC = 7.5 \text{ cm}$

Since,  $PQ \parallel BC$

$\therefore \angle APQ = \angle ABC$  (Corresponding angles are equal)

Now, in  $\triangle APQ$  and  $\triangle ABC$

$\angle APQ = \angle ABC$  (Corresponding angles)

$\angle A = \angle A$  (Common)

$\triangle APQ \sim \triangle ABC$  (AA similarity)

$$\therefore \frac{AP}{AB} = \frac{AQ}{AC} = \frac{PQ}{BC}$$

$$\therefore \frac{AQ}{AC} = \frac{3}{9} \Rightarrow \frac{AQ}{7.5} = \frac{1}{3} \Rightarrow AQ = \frac{7.5}{3} = 2.5 \text{ cm}$$

25. In  $\triangle ABC$  and  $\triangle DEF$

$$\frac{AB}{EF} = \frac{6}{4.5} = \frac{60}{45} = \frac{4}{3}, \frac{BC}{DE} = \frac{4}{3}$$

$$\Rightarrow \angle B = \angle E$$

$\therefore \triangle ABC \sim \triangle FED$  [By SAS similarity criterion]

26. We have  $\triangle ABC$  and  $\triangle PQR$  in which  $AD$  and  $PM$  are medians corresponding to sides  $BC$  and  $QR$  respectively

such that  $\frac{AB}{PQ} = \frac{BC}{QR} = \frac{AD}{PM}$

$$\Rightarrow \frac{AB}{PQ} = \frac{\frac{1}{2}BC}{\frac{1}{2}QR} = \frac{AD}{PM}$$

$$\Rightarrow \frac{AB}{PQ} = \frac{BD}{QM} = \frac{AD}{PM}$$

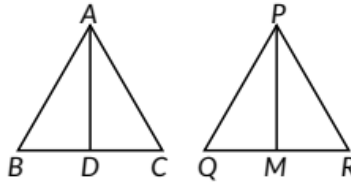

$\therefore$  Using SSS similarity, we have  
 $\triangle ABD \sim \triangle PQM$

$\therefore$  Their corresponding angles are equal.

$$\Rightarrow \angle ABD = \angle PQM \Rightarrow \angle ABC = \angle PQR$$

Now, in  $\triangle ABC$  and  $\triangle PQR$ ,  $\frac{AB}{PQ} = \frac{BC}{QR}$  ... (i)

Also,  $\angle ABC = \angle PQR$  ... (ii)

From (i) and (ii),

$\triangle ABC \sim \triangle PQR$ . [By SAS similarity]

27. Given: PA, QB and RC are each perpendicular to AC.

To prove:  $\frac{1}{x} + \frac{1}{y} = \frac{1}{z}$

In  $\triangle PAC$  and  $\triangle QBC$ ,

$\therefore BQ \parallel AP$

$\angle CPA = \angle CQB$  (Corresponding angles)

and  $\angle PCA = \angle QCB$  (Common angles)

$\therefore \triangle PAC \sim \triangle QBC$  (By AA similarity Criterion)

$$\Rightarrow \frac{AP}{BQ} = \frac{CA}{CB} = \frac{PC}{QC} \Rightarrow \frac{BQ}{AP} = \frac{CB}{CA}$$

$$\Rightarrow \frac{z}{x} = \frac{CB}{CA} \quad \dots (i)$$

Now in  $\triangle ACR$  and  $\triangle ABQ$ ,  $\therefore BQ \parallel CR$

$\angle ARC = \angle AQB$  (Corresponding angles)

and  $\angle RAC = \angle QAB$  (Common)

∴  $\triangle ACR \sim \triangle ABQ$

$$\therefore \frac{AC}{AB} = \frac{CR}{BQ} = \frac{AR}{AQ}$$

$$\therefore \frac{BQ}{CR} = \frac{AB}{AC}$$

$$\Rightarrow \frac{z}{y} = \frac{AB}{AC} \quad \dots(ii)$$

Adding (i) and (ii), we get

$$\frac{z}{x} + \frac{z}{y} = \frac{CB}{CA} + \frac{AB}{AC}$$

$$\Rightarrow \frac{z}{x} + \frac{z}{y} = \frac{CB+AB}{AC} \Rightarrow \frac{z}{x} + \frac{z}{y} = \frac{AC}{AC} = 1 \Rightarrow \frac{1}{x} + \frac{1}{y} = \frac{1}{z}$$

Hence proved.

28. (i) Given: Two similar triangles are ABC and PQR. CD and RS are medians of  $\triangle ABC$  and  $\triangle PQR$ .

To prove :  $\triangle ADC \sim \triangle PSR$

Proof:  $\frac{CA}{RP} = \frac{AB}{PQ} \quad [ \because \triangle ABC \sim \triangle PQR ]$

$$\Rightarrow \frac{CA}{RP} = \frac{2AD}{2PS} \quad (\text{Since } D \text{ and } R \text{ S are medians})$$

Now, In  $\triangle ADC$  and  $\triangle PSR$

$$\frac{CA}{RP} = \frac{AD}{PS}$$

and  $\angle A = \angle P \quad ( \because \triangle ABC \sim \triangle PQR )$

(By SAS similarity criterion)

$$\triangle ADC \sim \triangle PSR$$

Hence proved.

(ii) We have proved in part (i)  $\triangle ADC \sim \triangle PSR$

$$\therefore \frac{AD}{PS} = \frac{DC}{SR} = \frac{AC}{PR}$$

$$\Rightarrow \frac{AC}{AD} = \frac{PR}{PS} \Rightarrow AD \times PR = AC \times PS$$

Hence proved.

29. We have,  $\triangle BEA = \triangle CDA$

∴  $AB = AC$  and  $AE = AD$  [By C.P.C.T.]

$$\Rightarrow \frac{AB}{AD} = \frac{AC}{AE} \quad \dots(i)$$

Thus, in  $\triangle DEA$  and  $\triangle BCA$ , we have

$$\frac{AB}{AD} = \frac{AC}{AE} \quad \text{[From (i)]}$$

$$\angle BAC = \angle DAE \quad \text{[Common]}$$

$$\therefore \triangle DEA \sim \triangle BCA \quad \text{[By SAS similarity criterion]}$$

30. In  $\triangle ADE$  and  $\triangle ABC$

$$\angle ADE = \angle ABC \quad \text{[Given]}$$

$$\text{and } \angle DAE = \angle BAC \quad \text{[Common]}$$

$$\therefore \triangle ADE \sim \triangle ABC \quad \text{[By AA similarity criterion]}$$

$$\therefore \frac{AD}{AB} = \frac{AE}{AC} = \frac{DE}{BC}$$

$$\text{Now, } \frac{AD}{AB} = \frac{DE}{BC}$$

$$\Rightarrow \frac{AD}{AD+BD} = \frac{DE}{BC} \Rightarrow \frac{7.6}{7.6+4.2} = \frac{DE}{8.4}$$

$$\Rightarrow DE = \frac{7.6 \times 8.4}{11.8} = \frac{63.84}{11.8} = 5.4 \text{ cm}$$

31. Let  $AB$  be the lamp post and  $CD$  be the girl's height and  $DE = x$  be the length of the shadow of the girl.

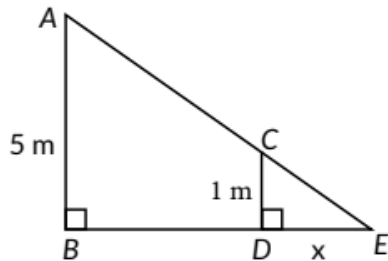

Here,  $CD = 100 \text{ cm} = 1 \text{ m}$ ,  $AB = 5 \text{ m}$

Speed of girl =  $1.9 \text{ m/s}$

We know that, Distance = Speed  $\times$  Time

Distance of the girl from the lamp post after 4 seconds,  $BD = 1.9 \times 4 = 7.6 \text{ m}$

In  $\triangle ABE$  and  $\triangle CDE$

$$\begin{aligned}
\angle B &= \angle D && \text{[Each } 90^\circ\text{]} \\
\angle AEB &= \angle CED && \text{[Common]} \\
\therefore \triangle ABE &\sim \triangle CDE && \text{[By AA similarity criterion]} \\
\therefore \frac{BE}{DE} &= \frac{AB}{CD} \\
\Rightarrow \frac{BD+DE}{DE} &= \frac{AB}{CD} && \text{[}\because BE = BD + DE\text{]} \\
\Rightarrow \frac{7.6+x}{x} &= \frac{5}{1}
\end{aligned}$$

We know that, Distance = Speed  $\times$  Time

Distance of the girl from the lamp post after 4 seconds,  $BD = 1.9 \times 4 = 7.6\text{m}$

In  $\triangle ABE$  and  $\triangle CDE$

$$\begin{aligned}
\angle B &= \angle D && \text{[Each } 90^\circ\text{]} \\
\angle AEB &= \angle CED && \text{[Common]} \\
\therefore \triangle ABE &\sim \triangle CDE && \text{[By AA similarity criterion]} \\
\therefore \frac{BE}{DE} &= \frac{AB}{CD} \\
\Rightarrow \frac{BD+DE}{DE} &= \frac{AB}{CD} && \text{[}\because BE = BD + DE\text{]} \\
\Rightarrow \frac{7.6+x}{x} &= \frac{5}{1} \\
\Rightarrow 7.6 + x &= 5x \Rightarrow 4x = 7.6 \Rightarrow x = 1.9
\end{aligned}$$

$\therefore$  Length of shadow of girl after 4 seconds is 1.9 metres.

32. In  $\triangle ABC$  and  $\triangle AMP$

$$\angle ABC = \angle AMP \text{ [Each } 90^\circ\text{]}$$

$$\angle BAC = \angle PAM \text{ [Common]}$$

$\therefore \triangle ABC \sim \triangle AMP$  [By AA similarity criterion]

$$\therefore \frac{CA}{PA} = \frac{BC}{MP} \quad \text{[Corresponding sides of similar } \triangle\text{'s are proportional]}$$

$$\Rightarrow CA \times MP = PA \times BC$$

33. Given, in  $\triangle PQR$ , N is a point on PR, such that QN  $\perp$  PR and PN.  $NR = QN^2$

To prove:  $\angle PQR = 90^\circ$

Proof: We have, PN. NR =  $QN^2$

$$\Rightarrow PN \cdot NR = QN \cdot QN$$

$$\Rightarrow \frac{PN}{QN} = \frac{QN}{NR}$$

In  $\triangle QNP$  and  $\triangle RNQ$ ,  $\frac{PN}{QN} = \frac{QN}{NR}$

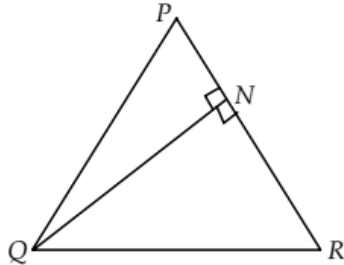

and  $\angle QNP = \angle RNQ$  [each equal to  $90^\circ$ ]

$\therefore \triangle QNP \sim \triangle RNQ$  [by SAS similarity criterion]

Then,  $\triangle QNP$  and  $\triangle RNQ$  are equiangulars.

i.e.,  $\angle PQN = \angle QRN$  ... (i)

and  $\angle RQN = \angle QPN$  ... (ii)

Adding (i) and (ii), we get

$$\angle PQN + \angle RQN = \angle QRN + \angle QPN$$

$$= \angle PQR = \angle QRN + \angle QPN \text{ ... (iii)}$$

We know that, sum of angles of a triangle is  $180^\circ$

$$\text{In } \triangle PQR, \angle PQR + \angle QPR + \angle QRP = 180^\circ$$

$$= \angle PQR + \angle QPN + \angle QRN = 180^\circ$$

$$[\because \angle QPR = \angle QPN \text{ and } \angle QRP = \angle QRN]$$

$$\angle PQR + \angle QPN + \angle QRN = 180^\circ \text{ [using (iii)]}$$

$$2\angle PQR = 180^\circ$$

$$\Rightarrow \angle PQR = \frac{180^\circ}{2} = 90^\circ \therefore \angle PQR = 90^\circ$$

Hence proved.

34. We have,  $\triangle ABC$  and  $\triangle DBC$  are on the same base BC.

Also, BC and AD intersect at O.

Let us draw  $AE \perp BC$  and  $DF \perp BC$ .

In  $\triangle AOE$  and  $\triangle DOF$ ,

$$\angle AEO = \angle DFO = 90^\circ \text{ ... (i)}$$

Also,  $\angle AOE = \angle DOF \dots(ii)$

[Vertically Opposite Angles]

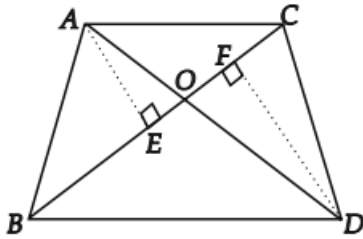

$\therefore$  From (i) and (ii), we get

$\triangle AOE \sim \triangle DOF$  [By AA similarity]

$\therefore$  Their corresponding sides are proportional.

$$\Rightarrow \frac{AE}{DF} = \frac{AO}{DO} \dots(iii)$$

$$\text{Now, } ar(\triangle ABC) = \frac{1}{2} BC \times AE$$

$$\text{And } ar(\triangle DBC) = \frac{1}{2} BC \times DF$$

$$\therefore \frac{ar(\triangle ABC)}{ar(\triangle DBC)} = \frac{\frac{1}{2} BC \times AE}{\frac{1}{2} BC \times DF} = \frac{AE}{DF} \dots(iv)$$

From (iii) and (iv), we have

$$\frac{ar(\triangle ABC)}{ar(\triangle DBC)} = \frac{AO}{DO}$$

Hence Proved.

35. Given,  $\triangle ABC$  is an isosceles triangle with  $AB = AC$

$\therefore \angle ABC = \angle ACB = \angle ABD = \angle ECF \dots(i)$

Now, in  $\triangle ABD$  and  $\triangle ECF$

$\angle ADB = \angle EFC$  [Each  $90^\circ$ ]

$\angle ABD = \angle ECF$  [Using (i)]

$\therefore$  By AA similarity criterion,  $\triangle ABD \sim \triangle ECF$ .

36. In  $\triangle ABC$ ,  $BC = 12$  cm,

$EH = DG = 6$  cm,

$BC = 12$  cm

$$\Rightarrow BF = FC = \frac{12}{2} = 6 \text{ cm}$$

and  $AF = 24$  cm,  $DE = GH$

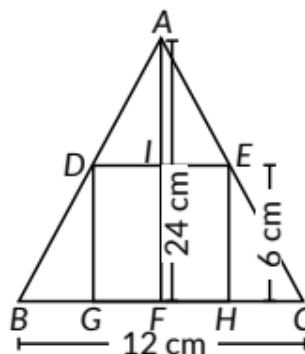

Now, in  $\triangle AFC$  and  $\triangle EHC$

$\angle AFC = \angle EHC$  [Each  $90^\circ$ ]

$\angle ACF = \angle ECH$  [Common]

$\therefore$  By AA similarity criterion,

$\triangle AFC \sim \triangle EHC$

$$\therefore \frac{AF}{EH} = \frac{FC}{HC} \Rightarrow \frac{24}{6} = \frac{6}{HC} \Rightarrow HC = \frac{6 \times 6}{24} = 1.5 \text{ cm}$$

Now,  $FH = FC - HC = (6 - 1.5) \text{ cm} = 4.5 \text{ cm}$

$GH = 2 \times FH = 2 \times 4.5 = 9 \text{ cm}$

Area of rectangle  $DEHG = \text{Length} \times \text{Width} = 6 \times 9 = 54 \text{ cm}^2$

37. Let  $AB$  and  $CD$  be two poles of height  $p$  and  $q$  metres respectively and poles are ' $a$ ' metres apart i.e.,  $AC = a$  metres.

Let  $AD$  and  $BC$  meet at ' $O$ ' such

that  $OL = h$  metres

Let  $CL = x$  and  $LA = y$

$\therefore x + y = a$

In  $\triangle ABC$  and  $\triangle LOC$ , we have

$\angle CAB = \angle CLO$  [Each  $90^\circ$ ]

$\angle C = \angle C$  [Common]

$\therefore \triangle ABC \sim \triangle LOC$  [By AA similarity criterion]

$$\therefore \frac{CA}{CL} = \frac{AB}{OL}$$

$$\Rightarrow \frac{a}{x} = \frac{p}{h} \Rightarrow x = \frac{ha}{p} \quad \dots(i)$$

In  $\triangle ALO$  and  $\triangle ACD$ , we have

$\angle ALO = \angle ACD$  [Each  $90^\circ$ ]

$\angle A = \angle A$  [Common]

$\therefore \triangle ALO \sim \triangle ACD$  [By AA similarity criterion]

$$\therefore \frac{AL}{AC} = \frac{OL}{DC} \Rightarrow \frac{y}{a} = \frac{h}{q} \Rightarrow y = \frac{ah}{q} \quad \dots(ii)$$

Now,  $x + y = ah \left( \frac{1}{p} + \frac{1}{q} \right)$  [From (i) and (ii)]

$$\Rightarrow x + y = ah \left( \frac{p+q}{pq} \right) \Rightarrow a = ah \left( \frac{p+q}{pq} \right) \Rightarrow h = \frac{pq}{p+q} \text{ metres.}$$

Hence, the height of the point of intersection of the lines joining the top of each pole to the foot of the opposite pole

is  $\frac{pq}{p+q}$  metres.

38. In  $\triangle ADC$  and  $\triangle BEC$

$\angle DC = \angle BEC$  [Each  $90^\circ$ ]

$\angle ACD = \angle BCE$  [Common]

$\therefore \triangle ADC \sim \triangle BEC$  [By AA similarity criterion]

In  $\triangle ADB$  and  $\triangle AEB$

$\angle ADB = \angle AEB$  [Each  $90^\circ$ ]

$\angle BAD + \angle EAB$

$\therefore \triangle ADB$  is not similar to  $\triangle AEB$ .

Again, in  $\triangle ADB$  and  $\triangle ADC$

$\angle BAD + \angle DAC$

$\angle ADB = \angle ADC$  [Each  $90^\circ$ ]

$\therefore \triangle ADB$  is not similar to  $\triangle ADC$

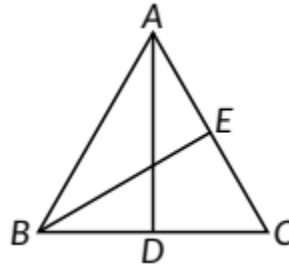

39. (d): In  $\triangle ABC$ ,  $AC^2 = AB^2 + BC^2$

$\Rightarrow AC^2 = 2^2 + 3^2$

$\Rightarrow AC^2 = 4 + 9$

$\Rightarrow AC = \sqrt{13}$  cm

So, perimeter is  $(2 + 3 + \sqrt{13})$  cm

$= (5 + \sqrt{13})$  cm which is irrational.

Hence, Assertion is false but Reason is true.

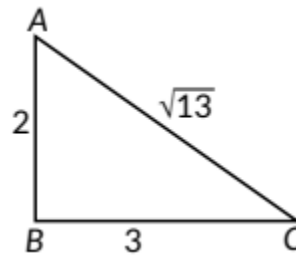

40. Let Aman starts from A point and continues 5 m towards west and reached at B point, from which he goes 12 m towards North reached at C point finally.

In  $\triangle ABC$ , we have

$AC^2 = AB^2 + BC^2$

$AC^2 = 5^2 + 12^2$

(By Pythagoras theorem)

$AC^2 = 25 + 144 = 169$

$\Rightarrow AC = 13$  m

So, Aman is 13 m away from his starting point.

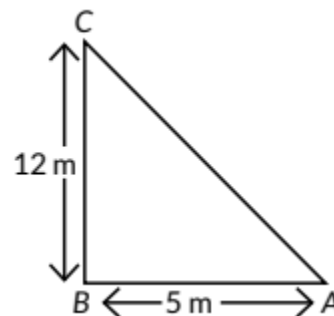

41.

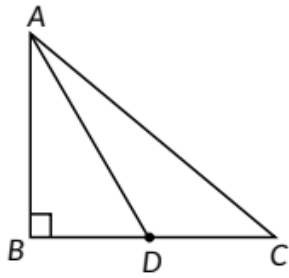

In  $\triangle ABC$ ,  $\angle B = 90^\circ$

$AB^2 + BC^2 = AC^2$  (By Pythagoras theorem)

$$\Rightarrow AB^2 = AC^2 - BC^2 \dots(i)$$

Similarly by Pythagoras theorem, In  $\triangle ABD$ ,

$$AD^2 = AB^2 + BD^2 \dots(ii)$$

$$\Rightarrow AB^2 = AD^2 - BD^2 \dots(iii)$$

From eqn (i) and (ii), we get  $AC^2 - BC^2 = AD^2 - BD^2$

$$\Rightarrow AC^2 = AD^2 - BD^2 + BC^2$$

As D is the mid point of BC,

$$\therefore BD = CD \text{ or } CD = \frac{1}{2}BC \quad [\because D \text{ is midpoint of } BC]$$

$$AC^2 = AD^2 - CD^2 + BC^2$$

$$AC^2 = AD^2 - CD^2 + (2CD)^2 [\because BC = 2CD]$$

$$\Rightarrow AC^2 = AD^2 + 3CD^2$$

Hence proved.

42. Let we have a rhombus ABCD.

$\therefore$  Diagonal of a rhombus bisect each other at right angles.

$\therefore OA = OC$  and  $OB = OD$

Also,  $\angle AOB = \angle BOC$  [Each =  $90^\circ$ ]

and  $\angle COD = \angle DOA$  [Each =  $90^\circ$ ]

In  $\triangle AOB$ , we have

$$AB^2 = OA^2 + OB^2 \dots(i)$$

(By Pythagoras theorem)

Similarly in  $\triangle BOC$ , we have

$$BC^2 = OB^2 + OC^2 \dots(ii)$$

In  $\triangle COD$ ,

$$CD^2 = OC^2 + OD^2 \dots(iii)$$

In right  $\triangle AOD$

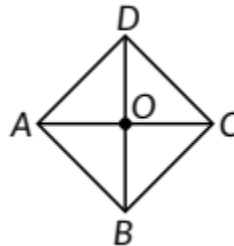

$$DA^2 = OD^2 + OA^2 \dots(iv)$$

On adding (i), (ii), (iii) and (iv), we get

$$AB^2 + BC^2 + CD^2 + DA^2$$

$$= [OA^2 + OB^2] + [OB^2 + OC^2] + [OC^2 + OD^2] + [OD^2 + OA^2]$$

$$= 2 [OA^2 + OB^2 + OC^2 + OD^2]$$

$$\therefore OA^2 = OC^2 \text{ and } OB^2 = OD^2$$

$$\Rightarrow AB^2 + BC^2 + CD^2 + DA^2 = 2[2OA^2 + 2OB^2]$$

$$= 2 \left[ 2 \left( \frac{1}{2} AC \right)^2 + 2 \left( \frac{1}{2} BD \right)^2 \right] \quad [\because O \text{ is mid point of } AC \text{ and } BD]$$

$$= 2 \left[ \frac{AC^2}{2} + \frac{BD^2}{2} \right] = AC^2 + BD^2$$

Thus, sum of the squares of the sides of a rhombus is equal to the sum of the squares of its diagonals.

43. In  $\triangle ABC$ ,  $BN$  and  $CM$  are medians and  $\angle A = 90^\circ$

To prove :  $4(BN^2 + CM^2) = 5BC^2$

In  $\triangle ABC$ ,  $\angle A = 90^\circ$

$$\therefore BC^2 = AB^2 + AC^2 \dots(i) \text{ (By Pythagoras theorem)}$$

In  $\triangle CAM$ ,  $\angle A = 90^\circ$

$$\therefore CM^2 = AC^2 + AM^2$$

$$\Rightarrow CM^2 = \left( \frac{1}{2} AB \right)^2 + AC^2 \quad [\because M \text{ is midpoint of } AB]$$

$$\Rightarrow CM^2 = \frac{1}{4} AB^2 + AC^2 \quad \dots(ii)$$

Now in  $\triangle BAN$ ,  $\angle A = 90^\circ$

$$\therefore BN^2 = AN^2 + AB^2 \quad (\text{By Pythagoras theorem})$$

$$\Rightarrow BN^2 = \left( \frac{1}{2} AC \right)^2 + AB^2 \quad (\because N \text{ is midpoint of } AC)$$

$$\Rightarrow BN^2 = \frac{1}{4} AC^2 + AB^2 \quad \dots(iii)$$

Add (ii) and (iii), we get

$$CM^2 + BN^2 = \frac{1}{4} AC^2 + \frac{1}{4} AB^2 + AB^2 + AC^2$$

$$\Rightarrow 4(CM^2 + BN^2) = 5(AC^2 + AB^2) = 5BC^2 \quad (\text{Using (i)})$$

Hence proved.

44. We have,  $\Delta ABC$  such that  $AD \perp BC$ .  $\Delta ABC$  intersect  $BC$  at  $D$  such that  $BD = 3CD$ .

In right  $\Delta ADB$ , by Pythagoras theorem, we have

$$AB^2 = AD^2 + BD^2 \dots(i)$$

Similarly in  $\Delta ACD$ , we have  $AC^2 = AD^2 + CD^2 \dots(ii)$

Subtracting (ii) from (i), we get

$$AB^2 - AC^2 = BD^2 - CD^2 \dots(iii)$$

Now,  $BC = DB + CD = 4 CD$  [ $\because BD = 3CD$ ]

$$\Rightarrow CD = \frac{1}{4} BC$$

$$\therefore BD = BC - CD = BC - \frac{1}{4} BC = \frac{3}{4} BC$$

Substituting the value of  $BD$  and  $CD$  in eqn.(iii) we get

$$AB^2 - AC^2 = \left[ \frac{3}{4} BC \right]^2 - \left[ \frac{1}{4} BC \right]^2$$

$$\Rightarrow AB^2 - AC^2 = BC^2 \left[ \left( \frac{3}{4} \right)^2 - \left( \frac{1}{4} \right)^2 \right]$$

$$= BC^2 \left[ \left( \frac{3}{4} + \frac{1}{4} \right) \left( \frac{3}{4} - \frac{1}{4} \right) \right] = BC^2 \left[ (1) \left( \frac{1}{2} \right) \right] = \frac{1}{2} BC^2$$

$$\Rightarrow 2AB^2 - 2AC^2 = BC^2 \text{ or } 2AB^2 = 2AC^2 + BC^2$$

Hence proved.

### CBSE Sample Questions

1.

In  $\Delta ABC$ , we have  $DE \parallel BC$

$$\therefore \frac{AD}{BD} = \frac{AE}{CE} \quad [\text{By B.P.T.}] \quad (1/2)$$

$$\Rightarrow \frac{3}{4.5} = \frac{2}{CE}$$

$$\Rightarrow CE = 3 \text{ cm} \quad (1/2)$$

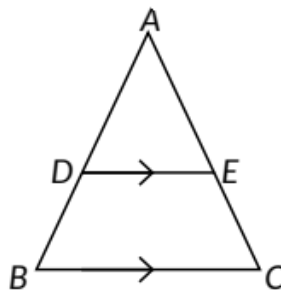

2. Consider  $\Delta ABC$  in which  $DE \parallel BC$ ,  $DE$  intersects  $AB$  at  $D$  and  $AC$  at  $E$ .

To prove:  $\frac{AD}{DB} = \frac{AE}{EC}$

Construction : Join BE, CD and draw  $EF \perp AB, DG \perp AC$ . (1/2)

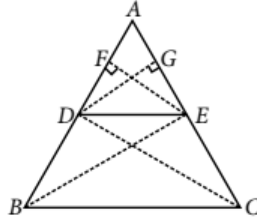

Area of  $\triangle EAD$

$$= \frac{1}{2} \times (\text{base} \times \text{height}) = \frac{1}{2} \times AD \times EF$$

So,  $\text{area}(\triangle EAD) = \frac{1}{2} AD \times EF$

Again, area of  $\triangle EDB = \frac{1}{2} \times (\text{base} \times \text{height})$

$$= \frac{1}{2} \times DB \times EF \tag{1}$$

So,  $\text{area}(\triangle EDB) = \frac{1}{2} DB \times EF$

$$\therefore \frac{\text{area}(\triangle EAD)}{\text{area}(\triangle EDB)} = \frac{AD}{DB} \tag{... (i)}$$

Similarly,  $\frac{\text{area}(\triangle EAD)}{\text{area}(\triangle ECD)} = \frac{AE}{EC} \tag{... (ii) (1)}$

Since, triangles EDB and ECD are on the same base DE and between the same parallel lines DE and BC. So,  $\text{area}(\triangle EDB) = \text{area}(\triangle ECD) \tag{... (iii) (1/2)}$

From (i), (ii) and (iii), we have  $\frac{AD}{DB} = \frac{AE}{EC} \tag{1/2}$

Using above theorem :

In  $\triangle ADB$

Since  $EO \parallel AB$

Using Basic Proportionality theorem

$$\frac{AE}{DE} = \frac{BO}{DO} \tag{... (i) (1/2)}$$

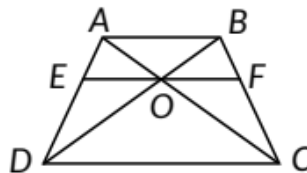

In  $\triangle BDC$

Since  $OF \parallel CD$

Using Basic Proportionality theorem

$$\frac{BO}{DO} = \frac{BF}{FC} \tag{... (ii) (1/2)}$$

Comparing (i) and (ii), we get

$$\frac{AE}{DE} = \frac{BF}{FC} \tag{1/2}$$

Hence proved.

3.

(d): Given,  $\frac{AB^2}{PQ^2} = \frac{4}{9} \Rightarrow \frac{AB}{PQ} = \frac{2}{3}$

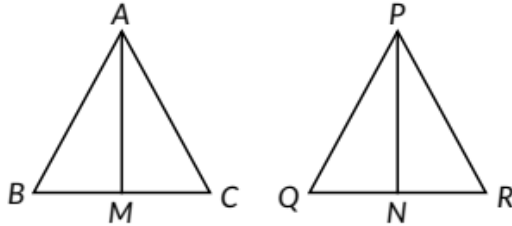

$$\therefore \triangle ABC \sim \triangle PQR$$

$$\therefore \frac{AB}{PQ} = \frac{BC}{QR} = \frac{AC}{PR} = \frac{AM}{PN}$$

$$\Rightarrow \frac{AB}{PQ} = \frac{AM}{PN} = \frac{2}{3} \quad (1)$$

4. (b): Since,  $DE \parallel BC \Rightarrow \triangle ABC \sim \triangle ADE$   
(By AA similarity criterion)

$$\text{So, } \frac{AD}{AB} = \frac{DE}{BC} \Rightarrow \frac{3}{7} = \frac{DE}{14} \Rightarrow DE = 6 \text{ cm} \quad (1)$$

5. (b):  $\triangle ABC \sim \triangle DEF$

$$\therefore \frac{\text{Perimeter of } \triangle ABC}{\text{Perimeter of } \triangle DEF} = \frac{BC}{EF}$$

$$\Rightarrow \frac{3+2+2.5}{\text{Perimeter of } \triangle DEF} = \frac{2}{4}$$

$$\Rightarrow \text{Perimeter of } \triangle DEF = 15 \text{ cm} \quad (1)$$

6. (c): In  $\triangle ACD$  and  $\triangle ABC$ , we have

$\angle A = \angle A$  (Common)

$\angle CDA = \angle BCA$  (Given)

$\therefore \triangle ACD \sim \triangle ABC$  (By AA similarity)

$$\therefore \frac{AC}{AB} = \frac{AD}{AC}$$

$$\Rightarrow \frac{8}{AB} = \frac{3}{8} \Rightarrow AB = \frac{64}{3} \text{ cm}$$

$$\text{So, } BD = AB - AD = \frac{64}{3} - 3 = \frac{55}{3} \text{ cm} \quad (1)$$

7. (b): AABE is a right triangle and FDGB is a square of side x cm (say).

In  $\triangle AFD$  and  $\triangle DGE$ ,  
 $\angle F = \angle G$  (Each  $90^\circ$ )  
 $\angle ADF = \angle DEG$   
 (Corresponding angles)

$\therefore \triangle AFD \sim \triangle DGE$   
 (By AA similarity)

$$\therefore \frac{AF}{DG} = \frac{FD}{GE}$$

$$\Rightarrow \frac{16-x}{x} = \frac{x}{8-x}$$

$$\Rightarrow 128 - 24x + x^2 = x^2$$

$$\Rightarrow 128 = 24x \Rightarrow x = \frac{16}{3} \text{ cm}$$

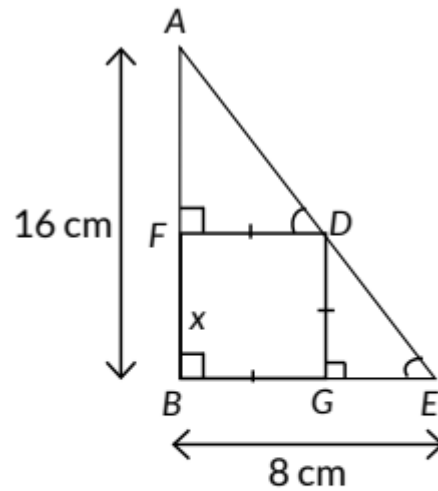

(1)

8.

(i) (c): Given scale factor =  $\frac{1}{4}$  and width of full size of boat = 60 cm.

$$\therefore \frac{1}{4} = \frac{\text{Width of scale model}}{60}$$

$$\Rightarrow \text{Width of scale model} = 15 \text{ cm.} \quad (1)$$

(ii) (d): They are not the mirror image of one another. (1)

(iii) (b): Their altitudes have a ratio a: b. (1)

(iv) (d): Since the two triangles are similar so the ratio of their corresponding sides are equal.

$$\therefore \frac{\text{Height of tree}}{\text{Shadow of tree}} = \frac{\text{Height of stick}}{\text{Shadow of stick}}$$

$$\Rightarrow \frac{12.5}{\text{Shadow of tree}} = \frac{5}{2}$$

$$\Rightarrow \text{Shadow of tree} = \frac{12.5 \times 2}{5} = 5 \text{ m} \quad (1)$$

(v) (c): Since E is the middle point of AT and F is the middle point of BT.

$$\text{So, } ET = \frac{AT}{2} = \frac{12}{2} = 6 \text{ m and } FT = \frac{BT}{2} = \frac{12}{2} = 6 \text{ m}$$

Now,  $\triangle ETF \sim \triangle ATB$  [By SAS similarity criterion]

$$\Rightarrow \frac{ET}{AT} = \frac{FT}{BT} = \frac{EF}{AB} \Rightarrow EF = 6 \text{ m} \quad (1)$$

9.

$$\begin{aligned} &\text{In } \triangle ABD, \\ &\angle 1 = \angle 2 \\ &\therefore BD = AB \quad \dots(i) \end{aligned}$$

$$\text{Given, } \frac{AD}{AE} = \frac{AC}{BD}$$

Using equation (i), we get

$$\frac{AD}{AE} = \frac{AC}{AB} \quad \dots(ii) \quad (1)$$

In  $\triangle BAE$  and  $\triangle CAD$ , by equation (ii),

$$\begin{aligned} &\frac{AC}{AB} = \frac{AD}{AE} \\ &\angle A = \angle A \quad \text{(common)} \\ &\therefore \triangle BAE \sim \triangle CAD \quad \text{[By SAS similarity criterion]} \quad (1) \end{aligned}$$

10. Given one side of first triangle is 9 cm.

Let the length of the corresponding side of the second triangle be x cm. (1)

Now, ratio of perimeter

$$= \frac{\text{Perimeter of first triangle}}{\text{Perimeter of second triangle}} = \frac{9}{x} \quad (1/2)$$

[:- In similar triangles, the perimeter of the triangle will be in the ratio of their corresponding sides.]

$$\Rightarrow \frac{25}{15} = \frac{9}{x} \quad (1/2)$$

$$\Rightarrow x = 5.4 \text{ cm} \quad (1)$$